

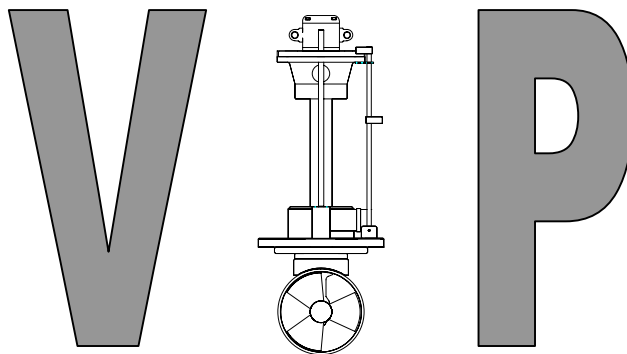

**VERTICAL RETRACTABLE THRUSTER**



# **VIP 250 HYDRAULIC**

**INSTALLATION OPERATION MAINTENANCE**

**Serial Number :** \_\_\_\_\_

**Date of Installation :** \_\_\_\_\_

**THIS MANUAL MUST BE KEPT ON BOARD AT ALL TIMES**

10 allée François Coli – F 06210 CANNES-MANDELIEU FRANCE.  
Tél. +33 (0)492 19 60 60 Fax + 33 (0)492 19 60 61  
[www.max-power.com](http://www.max-power.com) e-mail : [mp@max-power.com](mailto:mp@max-power.com)

## TABLE OF CONTENTS

Number	Description	Page
1.	POSITIONING .....	3
2.	DETERMINE THE LOCATION OF THE AUXILIARY EQUIPMENT .....	4
3.	MECHANICAL INSTALLATION	
3.1.	<i>MOUNTING BASE INSTALLATION</i> .....	5 - 6
3.2.	<i>CONSTRUCTION OF HULL OPENING &amp; CLOSING PLATE</i> .....	7
3.3.	<i>FINAL FITTING OF THE THRUSTER UNIT TO THE MOUNTING BASE</i> .....	7
3.4.	<i>FINAL ADJUSTMENT OF THE CLOSING PLATE</i> .....	8 - 9
4.	HYDRAULIC INSTALLATION .....	10
5.	ELECTRICAL INSTALLATION	
5.1.	<i>GENERAL</i> .....	11
5.2.	<i>POWER CABLE SELECTION</i> .....	11 - 12
5.3.	<i>POWER FUSE</i> .....	12
5.4.	<i>BATTERY REQUIREMENTS</i> .....	13
5.5.	<i>BATTERY ISOLATOR</i> .....	13
5.6.	<i>CONTROL CIRCUIT</i> .....	14
5.7.	<i>CONTROL PANEL AND THRUSTER CONTROL BOX FUNCTIONS</i> .....	15 - 16
6.	TESTS & CHECKS	
6.1.	<i>BEFORE LAUNCHING</i> .....	17
6.2.	<i>AFTER LAUNCHING</i> .....	17
7.	OPERATION LIMITATIONS .....	17
8.	BASIC MAINTENANCE	
8.1.	<i>CONTROL PANEL</i> .....	18
8.2.	<i>THRUSTER MOTOR &amp; RELAY</i> .....	18
8.3.	<i>BATTERIES</i> .....	18
8.4.	<i>COMPOSITE DRIVE LEG</i> .....	18
8.5.	<i>BRONZE DRIVE LEG</i> .....	19
8.6.	<i>GENERAL</i> .....	19
9.	DRAWINGS & DIAGRAMS	
9.1.	<i>BUILD DRAWINGS</i> .....	20
9.2.	<i>HYDRAULIC SYSTEM</i> .....	21
9.3.	<i>WIRING DIAGRAM</i> .....	22
9.4.	<i>ELECTRONIC CONTROL BOX CONNECTIONS</i> .....	23
9.5.	<i>WIRING LOOM OF MOTOR/RELAY UNIT</i> .....	24
9.6.	<i>POSITION SWITCH ADJUSTMENTS &amp; PARTS</i> .....	25
10.	PARTS LISTS & DIAGRAMS	
10.1.	<i>PARTS DIAGRAM:</i> .....	26
10.2.	<i>PARTS LIST:</i> .....	27
11.	WARRANTY COVERAGE .....	28 - 29
12.	DISTRIBUTER CONTACT LIST .....	30 - 31
13.	WARRANTY FORM .....	32

Your thruster is a high quality technical product and should be treated as such. The employment of a **qualified marine technician**, with experience in bow thruster installation, is strongly advised. Where possible, the boat manufacturer's architects, design departments and/or shipyards should be consulted, prior to the installation of the unit. For any boat requiring official classification, bodies of approval should also be consulted at the earliest opportunity. In any case, all other bodies, governmental or otherwise, should be contacted to ensure conformity with legal regulations relating to the boat in question.

**BEFORE STARTING THE INSTALLATION, IT IS RECOMMENDED TO CAREFULLY READ THE FOLLOWING GUIDE.**

## 1. POSITIONING

- Consider the following, when determining the position of the thruster unit in order to ensure the most efficient operation:
- Find the point the farthest forward (or aft), while keeping in mind the space available, given the vessel's fixtures, space and shape and while respecting the minimum immersion depth of one full turbine diameter (185 mm).

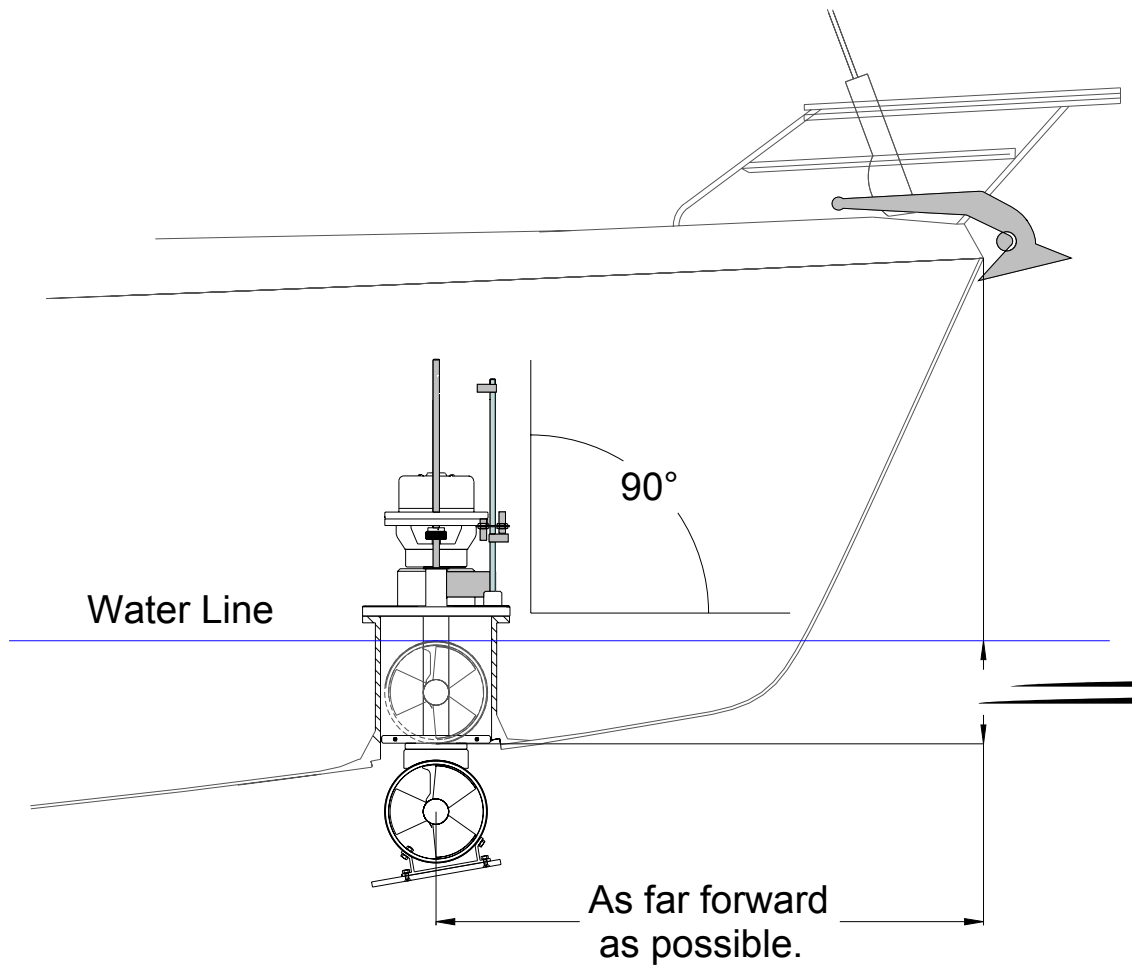

- Always check and make sure that there is enough room to allow for the complete removal of the VIP unit and enough room for the connection of the electric power cables. These cables must be able to flex freely without kinking when the VIP goes up and down.
- To install a VIP in the stern, make sure that the turbine flow is clear of all obstacles, or select the best possible compromise.

## 2. DETERMINE THE LOCATION OF THE AUXILIARY EQUIPMENT

- The hydraulic directional valve should be located near to the thrusters unit, in a horizontal position, installed in an accessible and dry place.
- The hydraulic oil reservoir must be located above and as near as possible to the hydraulic pump. The hydraulic oil must gravity feed the pump.
- The **electropump** (if used) must be as NEAR TO ITS BATTERIES AS POSSIBLE, it must have a reasonable supply of air for ventilation and must be KEPT DRY.
- A Max Power **main fuse**, of the correct size (*see section 4.3*), must be installed in the positive supply cable, as close as possible to the electropump battery bank and it must be easily accessible and clearly marked.
- A **manual battery isolator**, of the correct size, should be installed in the positive supply cable, as close as possible to the electropump battery bank and must be easily accessible and clearly marked

### VIP HYDRAULIC

#### General auxiliary equipment location

- |                              |  |
|------------------------------|--|
| 1 Thruster assembly          | 5 Control panel                                  |
| 3 Control box                | 6 Hydraulic oil reservoir with filtration system |
| 4 Hydraulic distribution DCV | 7 Electro hydraulic pump EHP                     |
|                              | 8 Power relay/power fuses                        |

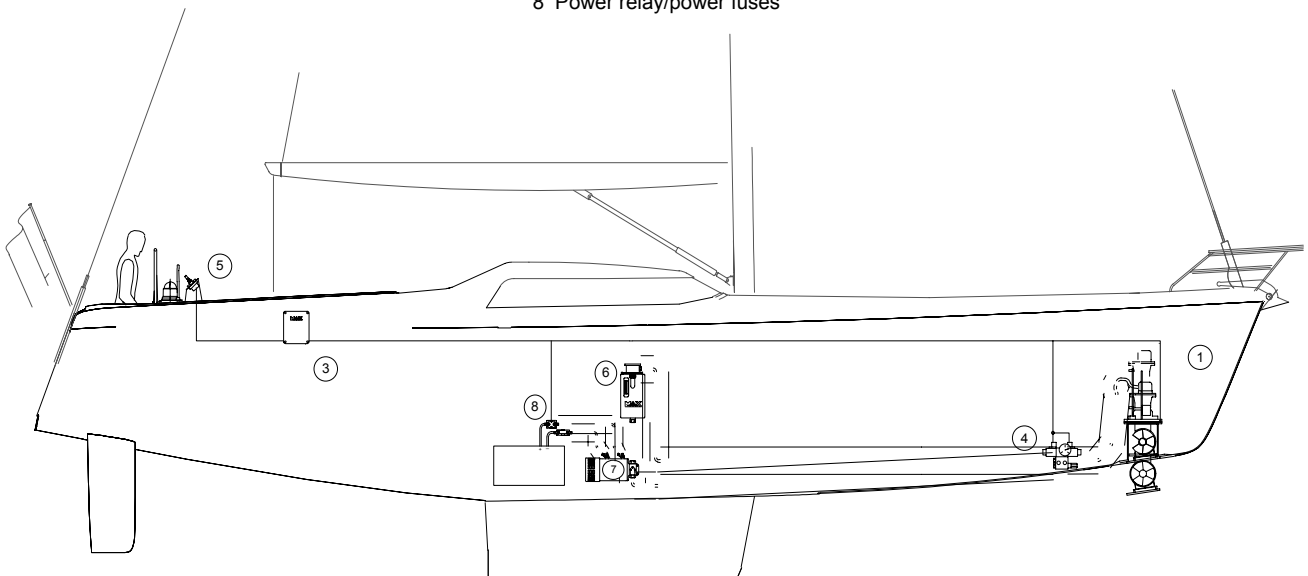

- An **electrical battery isolator**, as supplied by Max Power, should be installed in the positive supply cable, as close as possible to the electropump battery bank, in order to benefit from all automatic safety features of the electronic control system.
- The thruster **electronic control box** should be installed in proximity of the electropump unit in a completely dry and ventilated area.
- The **control panel(s)** should be installed as desired at the helm station(s) in a protected and waterproof manner.

### 3. MECHANICAL INSTALLATION

#### 3.1 MOUNTING BASE INSTALLATION

*(Please refer to "Build Drawing" at back of this document):*

- MAX POWER can supply, either a G.R.P. mounting base or a 5086 aluminium alloy-mounting flange. These bases save considerable shipyard time while assuring solid and precise installation.
  - a) For **GRP hulls** the mounting base should be laminated into the hull. The base supplied is only to help give the initial form; its strength will come from additional lamination (inside and out) added when laminating the hull.
  - b) For **alloy hulls** the mounting flange should be welded onto the base, which has been fabricated into the hull.
- The method and materials used for making the mounting base must be adapted to the particular hull material (laminated wood, GRP, sandwich, aluminium, or steel). Naval Architects, Classification Societies or specialised firms should be consulted.
- The thruster(s) mechanical stresses are spread over the hull by the mounting base. Its installation reinforces the hull, if well calculated, but it might be necessary to attach it by gussets to frames and stringers.
- When setting the mounting base, do not forget to take into account the overall dimensions of the VIP.

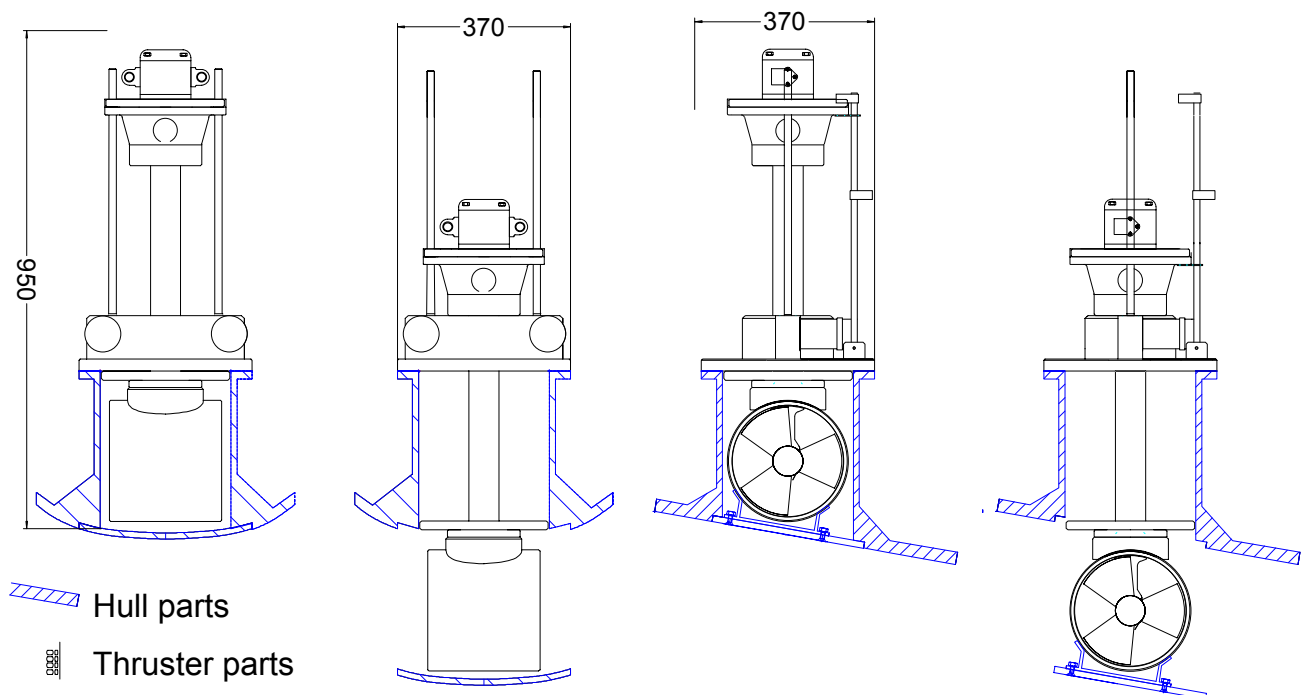

Total Unit Weight = 37kg

- The VIP pushes its thrust plate sideways against the inside of the mounting base when running. This means that one must totally lower the unit and check the following:

- (a) That the VIP's thrust plate is free to move up and down.
- (b) And also that there is no more than 2mm horizontal movement between the thrust plate and the mounting base, especially when fully down.

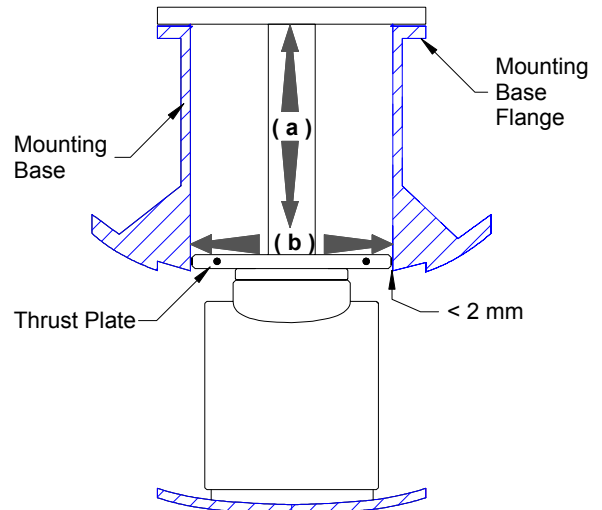

- The mounting base flange should be parallel to the waterline.
- In other words the thruster unit must be installed vertical with its turbine totally clear of the hull in the down position.

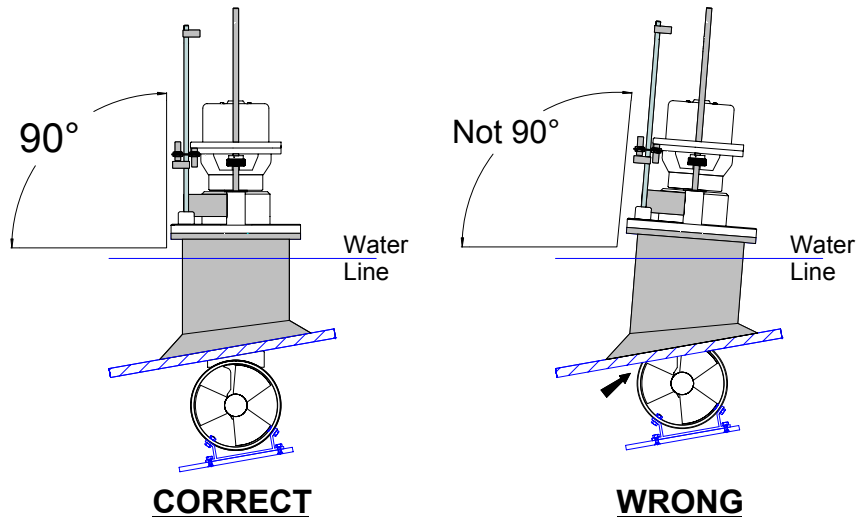

- Before fixing the thruster unit onto the mounting base flange it is important to ensure that the top surface of the mounting base flange is perfectly flat in order to accept the « O » ring seal of the VIP base flange in order to ensure perfect water tightness.
- The bolts fixing the VIP onto the mounting flange must be inserted from top to bottom. Provide sufficient access underneath the flange to allow for tightening the nuts. If the access is not possible, provide a special mounting flange with metric studs or tapped holes.

### 3.2 CONSTRUCTION OF HULL OPENING & CLOSING PLATE:

- The opening made for the thruster in the hull is closed by a plate, which can be made from the cutout hull section, or specially fabricated.

- The closing plate should fit into a 15 – 20 mm wide rebate in the hull when in the raised position. This is to transfer all the seas slamming forces to the hull and not to the electric rams!
- The closing plate must be securely fixed to the supplied adjustable aluminium-mounting fitting.
- A gasket must be installed in the hulls rebate. This gasket can be made either from neoprene or moulded in «SIKAFLEX» (or similar product). Precautions should be taken to ensure that the gasket does not stick to the closing plate. The plate must rest evenly on this gasket when the thruster is closed.

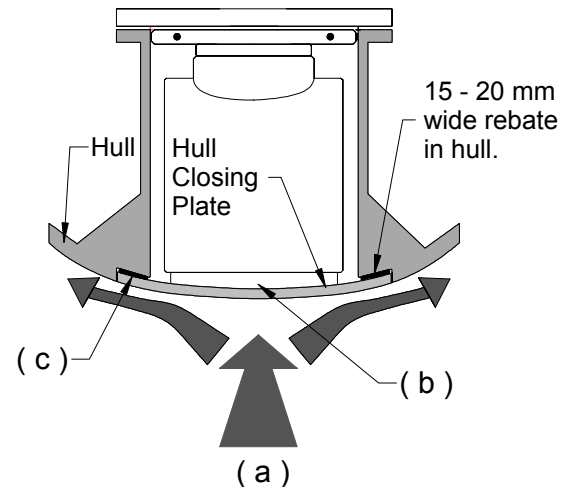

- To prevent marine growth inside the turbine enclosure, it is essential that once the unit is raised, no light be allowed to enter. On an excellent installation the enclosure may even be watertight. If this is achieved anode life will be greatly increased (No circulating water, no oxygen and no corrosion!).
- The use of antifouling or other paints on the thruster unit is not necessary **if** the closing plate closes properly onto its seal.

⚠ However, **if** painted, never use copper based paints and do not paint the vertical column of the unit.

### 3.3 FINAL FITTING OF THE THRUSTER UNIT TO THE MOUNTING BASE:

- Final installation of the thruster unit onto the mounting base must be made after thoroughly cleaning and then liberally coating both joint surfaces (thruster base flange and mounting base flange) with good quality marine grease. This is so that the «O» ring seal is compressed flat, evenly, smoothly and squarely when the bolts are tightened.
- Under no circumstances should the thruster be glued or bedded down with a marine type mastic/glue such as Sikaflex or other similar product(s).
- The flange bolts should be tightened sequentially and in successive passes until the two surfaces touch.

### 3.4 FINAL ADJUSTMENT OF THE CLOSING PLATE:

- Once the thruster is permanently bolted onto the mounting base, reinstall the closing plate to do the final adjustments.

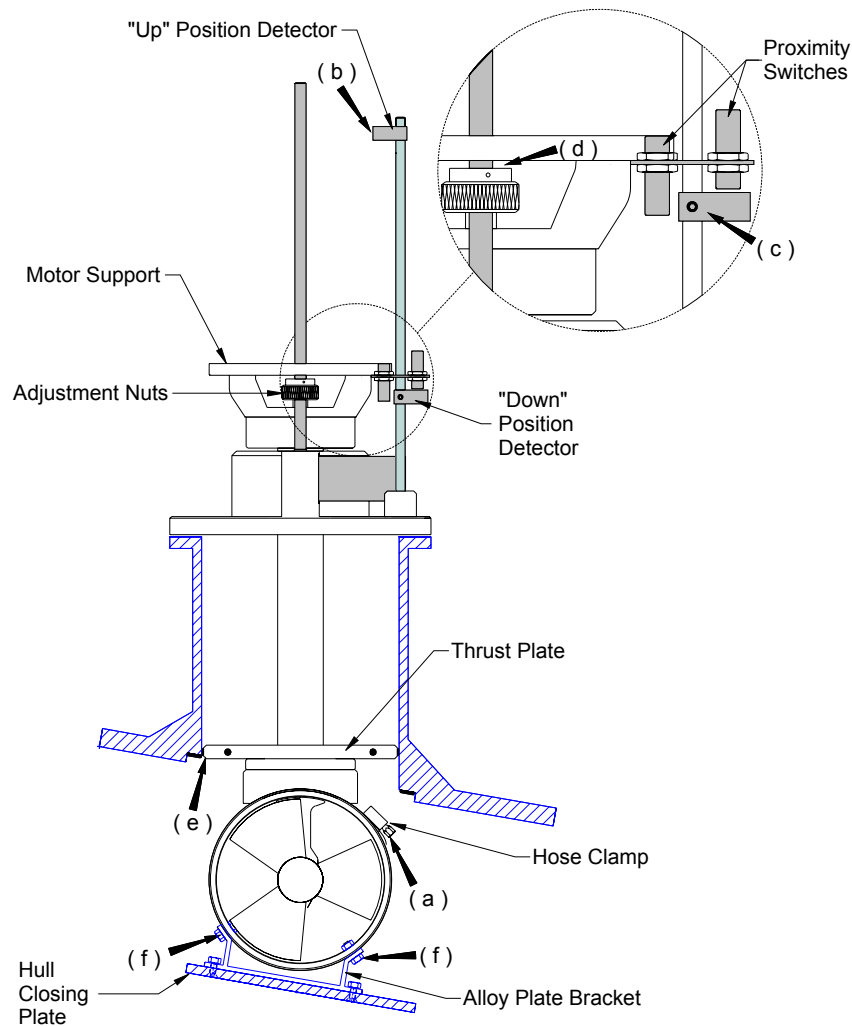

- Lower and raise the turbine to determine correct position of the hull closing plate so that it fits evenly and squarely in the rebate in the hull, then tighten the hose clamps (delivered with unit). The closing plate must rest evenly on its gasket, with pressure so that no upwards movement of the plate is possible even in heavy sea conditions when the hull is subjected to slamming forces.
- Once the hull closing plate adjustment has been completed, adjust the "up" position detector and tighten its grub screw with a 2.5 mm Allen key. This should be done with the unit fully retracted.
- Note that the down position detector is pre-adjusted (before leaving the factory) and should not be touched.
- If re-adjustment is necessary, care should be taken to re-adjust the detector so that adjustment nuts do not touch the motor support when fully down and that the detector grub screw (2.5mm Allen key screw) is tightened down after re-adjustment.



- e) The thrust plate should not protrude from the mounting base, since it absorbs the horizontal stresses when thrusting or manoeuvring. If protruding, adjust the down position detector as described above.
- f) When finished with the final adjustments, fix the alloy plate bracket by bolting through the GRP turbine in addition to the cable clamps.

-  **IMPORTANT:** Please keep in mind that the power supply to up/down motors is not automatically interrupted if the proximity switches do not detect the position detectors. Care must therefore be taken to remove ones finger from up or down button as soon as the unit blocks in fully up or fully down position when closing plate adjustments are done and if position detectors are not adjusted yet.
- **Installation Advice:** In order to make sure that VIP is raising and lowering smoothly and when closing plate adjustments are made, one can do the following:

- a) Connect 12V/24V directly to the two up/down motors (depending on up / down motor voltage) and simply reverse the polarity to change direction (raise/lower).

 **Note.** The Drive Screws rotate in opposite directions, therefore the motors must turn in opposite directions. If a supply is going to be directly fed to the up / down motors for ease of installation, then the positive of one motor should be connected to the negative of the other motor and vice versa.

 It is **important** to install a 10A fuse in the positive cable and to keep in mind that wires need to be disconnected as soon as the up or down position is reached or as soon as the unit blocks. to avoid damaaina the up/down motors.

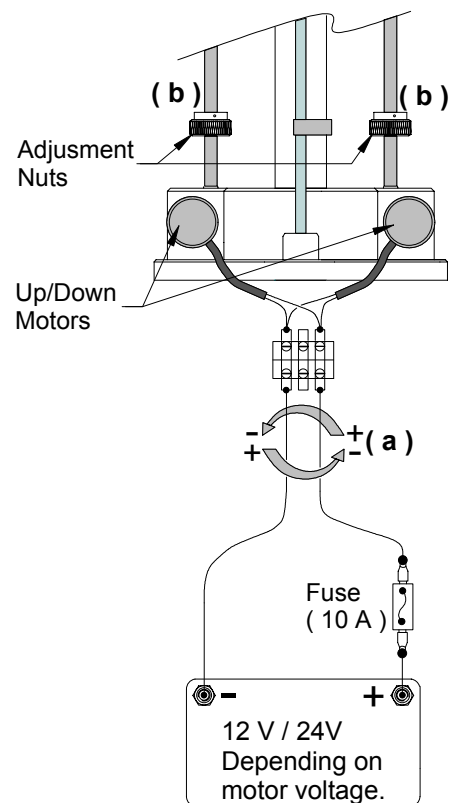

If the unit blocks before reaching the up/down position or if the unit vibrates excessively when going up/down one needs to adjust the two adjustment nuts to ensure the unit is completely vertical to its base.

#### 4. HYDRAULIC POWER SYSTEM INSTALLATION

- The hydraulic power equipment, such as the oil reservoir/filter, pump and directional control valve, should be installed in compliance with the usual rules of accessibility to enable periodic checks and maintenance.
-  Remember that:
  - (1) The oil tank must gravity feed to the pump.
  - (2) The directional control valve must be fitted as close as is convenient to the thruster unit, in order to verify the hydraulic pressure gauge.
- All hydraulic high pressure power circuit piping must comply with high pressure standards (Flexible hose – HP SAE 100 R8 or R9), and have a diameter at least equal to that recommended in order to reduce head loss especially when the installation's layout requires long hose lines. These hoses or pipes should preferably have 1/2" interior diameter.
- No hose, pipe or fitting in the power circuit should ever have an interior diameter less than 3/8".
- All power circuit piping must have a service pressure rating of at least 250 bar, with a rupture pressure rating of 500 bar.
- Fittings must be of good quality and crimped as per manufacturers instructions, and pressure tested to at least 400 bar.
- **All pipes and hoses must be absolutely clean when connected to the circuit!**
- The pump intake hose line (from the reservoir) must be of a quality that is not subjected to pinching or crimping due either to vacuum, to an excessively small radius of curvature, or to variations of temperature.
- This hose or pipe should **always be shorter** than 2 meters and preferably have 1" interior diameter but not less than 3/4"ID

MAX POWER recommends the use of **ISO GRADE 15 to 32 hydraulic oils** for the hydraulic power circuit. Max Power has already used this oil during the run in tests and consequently the Thrusters motor and piping are already filled with such.

**CAUTION:** Biodegradable and mineral (commonly used) oils are non-compatible and should not be mixed or used together. Mixing them will deteriorate certain hydraulic elements. If you intend to use biodegradable oil, thoroughly flush the existing mineral oil from the unit first with the appropriate oil.

## 5 ELECTRICAL SYSTEM INSTALLATION

- It is important that a qualified marine electrician does the electrical installation, since an incorrect electrical installation will result in the rapid deterioration and/or failure of the unit.
- All electrical components (Electro Hydraulic Pump, Directional Control Valve, Electronic Control Box, etc.) should be installed in dry and ventilated areas.
- Under no circumstances should any inflammable products be stored next to the electrical components of the thruster.
- When choosing cable sizes and the battery bank size and type, special care should be given to voltage drops, since excessive voltage drops will cause premature failure of motors and relay contacts.
- Great care should be taken to correctly tighten all electrical connections.

Voltage drops in the power circuit will cause relay and brush failure. Special attention must be given to the battery's quality, capacity and condition, and correct cable sizes must be selected.

The minimum voltage should be 21V at the Electro Pump terminals with the thruster running, boat in water and batteries being charged.

The installation of a manual and/or electric battery isolator and power fuse in the Electro-Pump's positive power line is essential.

Please Note: When using a manual battery isolator it must be visible, clearly marked and easily accessible.

The Electro-Pump does not have a specific polarity.

### 5.2 POWER CABLE SELECTION (for Electro pump models):

- According to the ISO 10133 standards: *"The length and cross sectional area of conductors in each circuit shall be such that the calculated voltage drop shall not exceed 10% of the nominal battery voltage at any appliance if the circuit is switched on at full load"*.
- The cable lengths as given in the table below are the total length of the positive cable, measured from the thuster battery bank to the thruster, plus the total length of the negative cable measured from the thruster back to the battery bank.
- When choosing or calculating the cable size needed for your thruster installation, do not forget to take into account the thermal rating of the conductor insulation which are directly related to the ampacity (current carrying capacity) of the cable. Always try to use cables with the highest thermal insulation rating available or at least 85° - 90°C.

Cable lengths To and from batteries/relay	VIP 250 DUO HYD
1 m (2 x 0.5m)	95 mm <sup>2</sup>
3 m (2 x 1.5m)	120 mm <sup>2</sup>
5 m (2 x 2.5m)	150 mm <sup>2</sup>
10 m (2 x 5m)	190 mm <sup>2</sup>

For large diameter cables it may be easier to use two smaller cables instead (in order to allow for a greater flexibility of movement). For example: 2 x 50 mm<sup>2</sup> instead of 95 mm<sup>2</sup>. Cables at thruster unit should be free to move, without kinking when VIP goes up and down

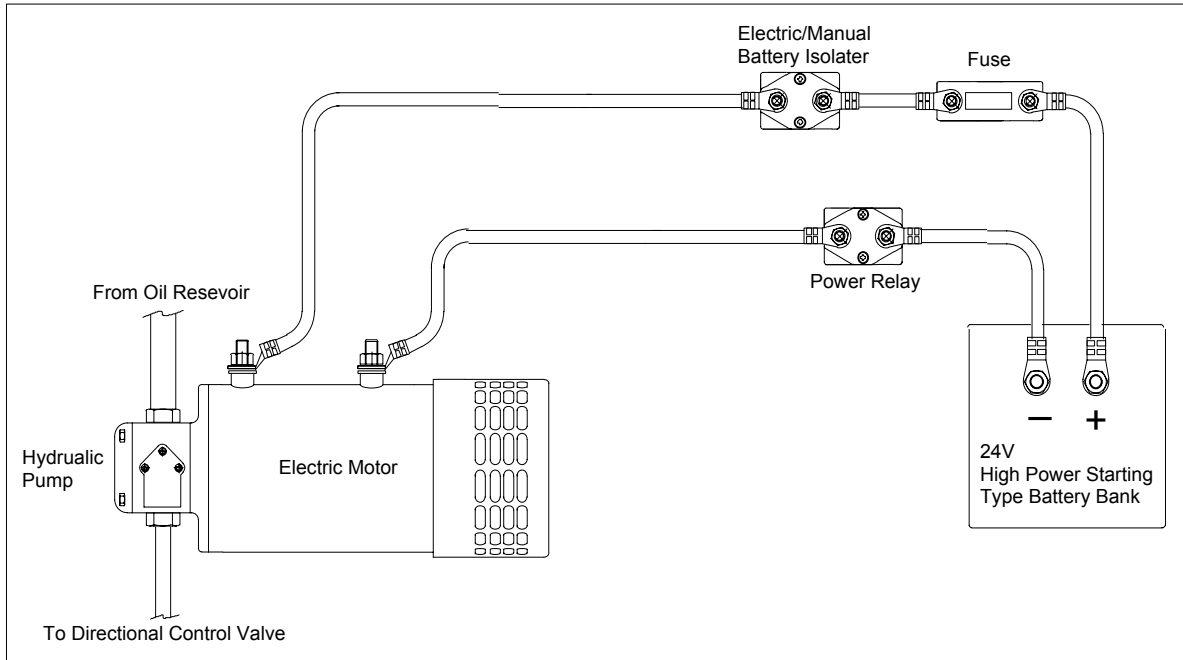

**5.3 POWER FUSE:**

- Sizing of fuses for overcurrent protection are a function of the cable sizes in the circuit, not the amperage drawn by the appliance (electropump motor) in the circuit. It is thus not the electropump motor that is protected by the fuse, but the power cables supplying the thruster motor.
- The Max Power fuse has been application selected for it's time and current characteristics, consequently a much lower rated fuse than traditionally rated may be fitted. Max Power recommends the following fuses and fuse holders as supplied by Max Power:

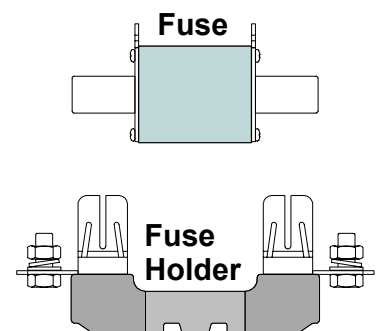

	VIP 150 Hydraulic
Max Power Fuse Size	315 A
Regular Fuse Rating	600 A
Max Power Part Number for fuse.	OPTI 3121
Max Power Part Number for fuse holder.	OPTI 3091

#### 5.4 ELECTROPUMP BATTERY REQUIREMENTS :

- When choosing the type of batteries needed for your thruster's battery bank, keep in mind that it is the **CCA** (Cold Cranking Amps) capacity that is the most **important** and not the Ah (Amp-hour) capacity. This is because thrusters draw high currents, but only for very short periods of time (maximum 3 min.)

VIP 250 Hydraulic 24V	
Type of Batteries	Exide, Maxxima 900
Number of Batteries	4 to 6
Type of Connection	Series/Parallel

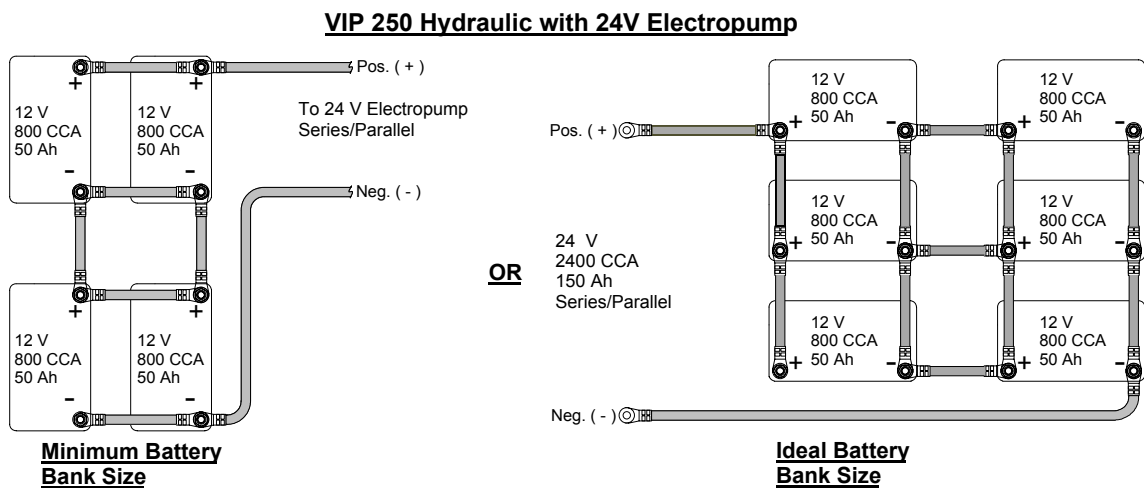

- If the dedicated batteries are charged by the alternator, the reference of the charge must be taken after the diode-splitting block (if in doubt, consult a marine electrician).
- If the batteries or cables are inferior to those recommended, the VIP will not reach its potential thrust. The greater the batteries and cables size, the better the thrust.
- Do not ground the VIP.

#### 5.5 BATTERY ISOLATOR:

- A **manual battery isolator**, of the correct size, should be installed in the positive supply cable, as close as possible to the thruster battery bank and should be easily accessible and clearly marked.
- An **electrical battery isolator**, as supplied by Max Power, should also be installed in the positive supply cable, as close as possible to the thruster battery bank, in order to benefit from all automatic safety features of the electronic control system.

**5.6 CONTROL CIRCUIT:**

- A double pole isolator/breaker clearly marked “Thruster” should be installed on the yacht’s main equipment breaker board in order to isolate the control circuit and/or electropump power circuit, when thruster is not in use.
- This isolator/breaker should ideally be supplied from an independent battery bank, to the one used for powering the thruster unit.
- Please note that VIP thrusters equipped with an “electronic control box” can only be used with Max Power’s range of control panels as shown in this manual.
- The VIP electronic controller can be supplied by either 12V or 24V – depending on the up/down motor specification.
- The installer must protect the positive supply cable of the VIP electronic control box by means of a fuse as indicated in the drawing below. The size of the supply wires (red & black) depends on the length of the cable run and the voltage drop in these cables should not exceed 5% of the nominal battery voltage.
- For safety reasons and in order to benefit from all the functions provided by the VIP electronic controller, an electric battery isolator must be installed in the thruster motor’s positive supply cable.

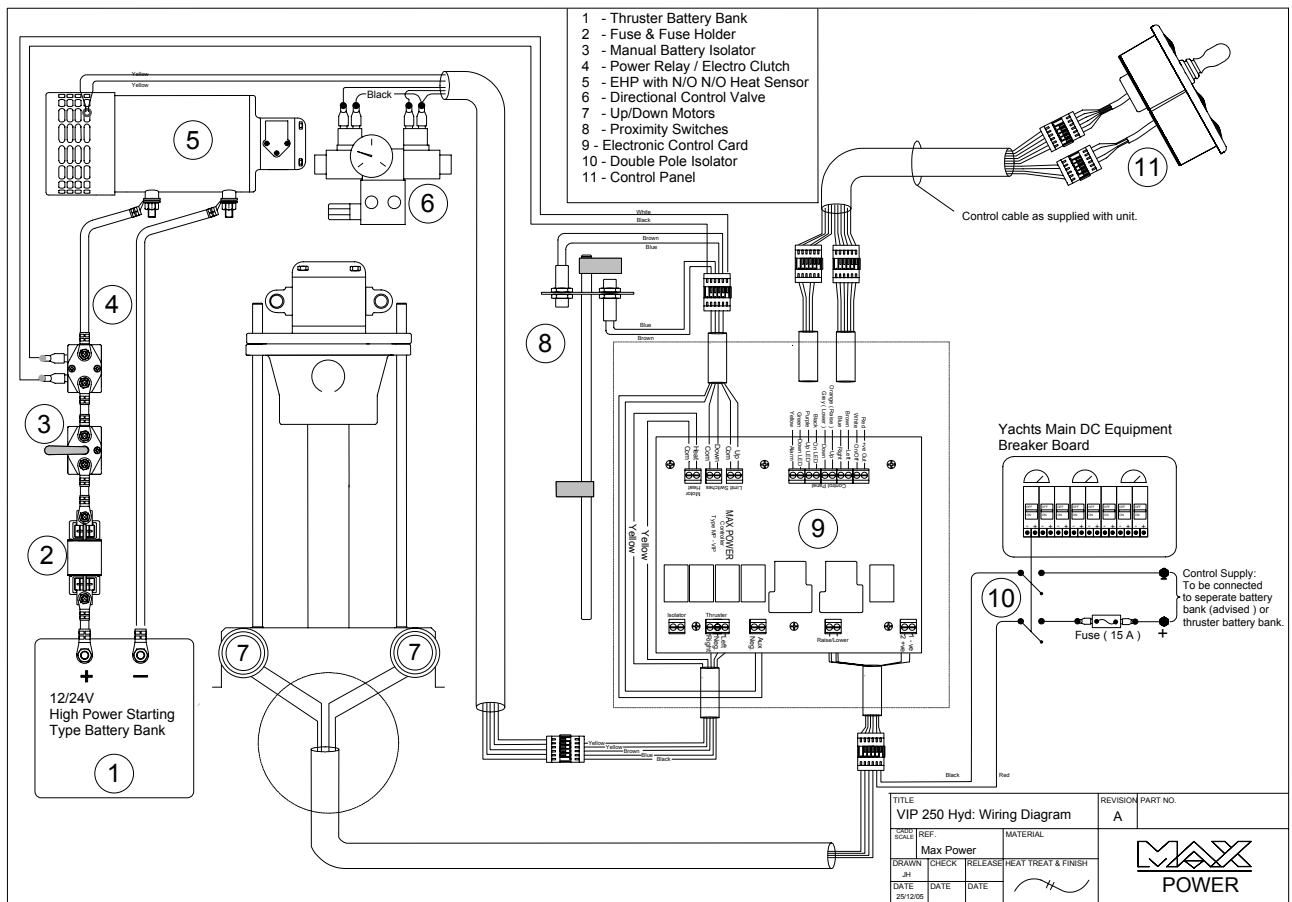

Please refer to the drawings “Wiring Diagram”, “Wiring Loom of Motor/Relay Unit” and “Electronic Control Box Connections” in the back of this manual for more detail on the complete wiring installation.

## 5.7 CONTROL PANEL AND THRUSTER CONTROL BOX FUNCTIONS:

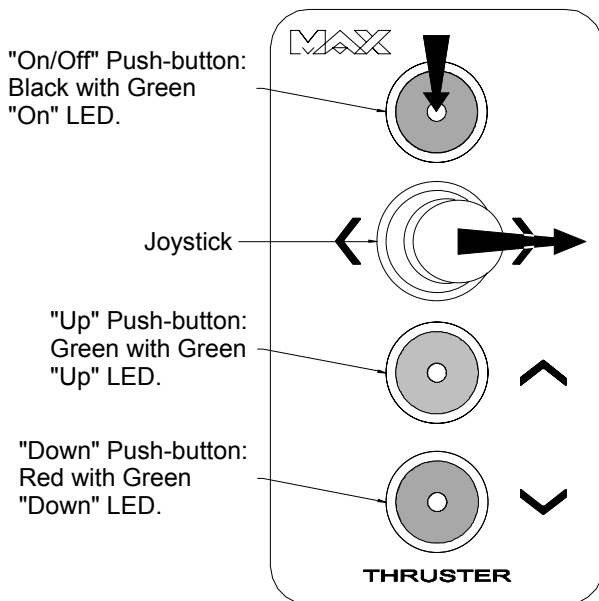

### Control Panel:

To switch "ON" or "OFF" push down the black push-button, while pushing joystick to the right for one second.

To "Lower" or "Raise" press and hold the "Down" or "Up" pushbutton until buzzer in control panel double beeps, which indicates unit has reached fully down or fully up position..

### 5.7.1 Switching System "On" or "Off":

- To switch the thruster "ON" or "OFF" follow the instructions on the diagram above.
- When switched "ON" the unit will double beep and the LED's in the black and green push buttons will light up.
- When switched "OFF" the unit will double beep and the LED's will go out. It's only possible to switch off the unit with thruster in the fully up position.

### 5.7.2 "Lowering" & "Raising" Thruster Unit:

- Once the unit has been switched on, as described above, press and hold the "Down" pushbutton to lower. The buzzer will start beeping and the "Down" LED will start to flash as soon as the thruster leaves the up position.
- If "Down" or "Up" pushbutton is released before "Down" or "Up" position is detected, the buzzer will start to beep (short) once every 1/2 second and both "Up" & "Down" LED's will start flashing.
- When thruster is detected to be fully down, the "Down" LED comes on and the buzzer double beeps to indicate that thruster is completely down and ready to thrust.
- As long as the thruster is in the "Down" position the buzzer will beep (short) once every three seconds, to indicate that thruster is still in the down position.
- To raise thruster, press and hold the "Up" pushbutton. When thruster is detected to be fully up the "Up" LED comes on and the buzzer double beeps to indicate that thruster is completely up and ready to be switched off.

### 5.7.3 Thrusting "Left" or "Right":

- a) Use joystick to thrust either left or right.
- b) Please note that it is only possible to thrust left or right when thruster is detected to be fully down.
- c) The thruster controller provides a time delay between left and right thrust in order to avoid rapid direction changes, but no delay when thrusting to same side.

### 5.7.4 Overheat Alarm & Shut-Down:

- a) If the thruster motor overheats the "On" LED will flash with one-second intervals until the motor has cooled down.
- b)  During this overheat condition one has a total of ten seconds of actual use (left & right thrust) of the thruster, after which it will not be possible to continue thrusting in either direction.
- c) The thruster must then be raised by pushing the "Up" push button. Once thruster is detected to be fully up the system will automatically switch off.
- d) After this overheat shut down it will not be possible to switch "On" the system again until the thruster motor has cooled down.

### 5.7.5 General:

- a) If the thruster unit is in the "Up" position and has not been used for a period of ten minutes, the unit will automatically switch off. Before automatically switching off the unit will warn you by beeping once, followed by a second beep a few seconds later, after which the unit switches off.
- b) In order to isolate the power circuit of the electropump each time the control circuit is switched off, one would need to install an electric battery isolator, as advised by Max Power (see "*Wiring Diagram*" in the back of this manual for more detail).
- c) When electronic control box is powered up and "Up" position detector is not detected, the "Up" LED will start flashing and the buzzer will beep once every second. The "Up" push-button should then be pressed until unit is detected to be fully "Up". After which the buzzer will beep twice and the system will be switched off automatically.



## 6. TESTS and CHECKS

### 6.1 BEFORE LAUNCHING:

- a) Check all fittings for tightness and leaks
- b) Raise and lower thruster.
- c) Check operation of the DCV
- d) Check that the hull closing plate shuts firmly.
- e) Confirm that all bolts have been sufficiently tightened, especially the base bolts.
- f) Correct the adjustment of the position detectors, if needed.
- If the up/down motors function the wrong way round, reverse the two wires connected to the up/down motors.
-  Never test the thruster to the left or right with the boat out of the water..

### 6.2 AFTER LAUNCHING:

- a) Check the water tightness of the thruster installation.
- b) Fill the hydraulic power circuit taking care never to let the pump run dry
- c) Turn on power to both circuits (power and control).
- d) Purge the system by executing a few short left and right manoeuvres, check the hydraulic oil tank and refill if necessary.
- e) Check the operation of the Directional Control Valve.
- f) Thrust tests must be carried out under NORMAL conditions:
  - with the batteries fully charged and in good condition.
  - with the engine running and the alternator charging the batteries.
- g) Check thrust direction: With the joystick to the left (port) the vessel should move to the port and conversely. If the direction is not correct then inverse the connections on the hydraulic Directional Control Valve.
- h) Check the Voltage at the electropump (if fitted) You should not read less than 21V
- i) Check the hydraulic pressure on the DCV under load, the pressure should be in the order of 130 to 140 Bars. The relief valve has been factory set and should not require adjustment.

 Close Pressure valve after checks.

## 7. OPERATION LIMITATIONS

- Never leave the **VIP** in the down position when not in use. Any calcium, or shellfish deposits that accumulate after a long period in the down position will deteriorate the column's water seal.
-  The **VIP** must be in the up position during normal navigation. The **VIP** should only be used under conditions with less than 5 knots forward speed.
- Please note that the electropump motor of the VIP is rated S2-2min. This means the motor can run continuously for 2 minutes, after which it should be stopped for a sufficient time to cool down to the ambient temperature.
- Please keep in mind that the supply to the up/down motors is not automatically interrupted if the proximity switches do not detect the position detectors. Care must thus be taken to remove ones finger from the up or down button as soon as unit blocks, before fully up or down positions are reached.
- The **VIP** thruster should always be used when the batteries are fully charged and the with the engine alternator running. Discharged batteries will damage the electropump motor.

## **8. BASIC MAINTENANCE:**

### **8.1 CONTROL PANEL:**

- a) Control panel(s) should be protected from the natural elements while the thruster is not in use.
- b) The area behind the dashboard should be kept dry at all times to avoid the risk of oxidation of the cable connector contacts.

### **8.2 HYDRAULICS:**

- a) Check hydraulic oil reservoir level.
- b) Check hydraulic hoses for chafing, kinking and leaks.

### **8.3 BATTERIES:**

- a) Check regularly the condition of the batteries used for the thruster and its charging system.
- b) Weak batteries (low voltage) may cause of deterioration of the electropump.

### **8.4 COMPOSITE DRIVE LEG:**

- a) The composite drive leg is lubricated for life
- b) The composite drive leg does not require an anode.
- c) When the boat is ashore, check for evidence of fishing line, etc... in the propellers.
- d) For prevention of calcium build up on the drive shafts, which would damage the oil seals, before fitting the propeller(s), cover drive shaft and the oil seals stainless steel cover with silicon grease. This should be done on an annual basis after cleaning of outside of leg.
- e) Do not use aggressive solvents as they might damage drive leg seals.
- f) If drive leg oil seals are found to be worn, replace drive leg with exchange unit.
- g) Always keep the propellers and tunnel clean.
- h) Please contact your closest Max Power distributor for local service points.

## 8.5 BRONZE DRIVE LEG:

- a) Check the oil in the leg every year, and change if necessary (oil drain plug is under the anode - copper joint should be changed).
- b) The anode should be frequently checked and changed when necessary (At least every year).
- c) When the boat is ashore, check for evidence of fishing line, etc... in the propellers.
- d) For prevention of calcium build up on the drive shafts, which would damage the oil seals, before fitting the propeller(s) cover drive shaft and oil seals, with silicon grease. This should be done on an annual basis after cleaning of outside of leg.
- e) Do not use aggressive solvents as they might damage drive leg seals.
- f) Always keep the propellers and tunnel clean.
- g) Do not paint the anode.
- h) Please contact your closest Max Power distributor for local service points.

## 8.6 GENERAL:

- a) Regularly check that the power cable connections are tightened correctly and that they are free to move when VIP is going up/down, and that they are in good condition.
- b) If the vessel is to remain out of the water for some time, for example dry storage for winter, the underwater mechanism must be thoroughly rinsed with fresh water, then the thruster column must be liberally greased.
- c) Inspect and repair the hull closing plate gasket for deterioration or missing pieces. Check and tighten, if necessary, the hull fixing plate bracket screws.
- d) Every two years drain the entire hydraulic oil system, clean and replace filters and recharge the hydraulic system with new oil.
- e) Every two years change column seal, part number 52 on parts list.
- f) Every five years complete removal of unit and return to factory or authorised dealer for full service, which include
  - Complete overhaul of the unit, replacement of column seal, bearings, bushes oil seals etc
  - Service of complete hydraulic oil system including pump, distributor, etc.

For more detailed maintenance procedures, please contact your closest Max Power distributor (See "*Distributor Contact List*") for further assistance.

**A copy of this manual must remain  
on board for consultation.**

9. **DRAWINGS & DIAGRAMS:**

9.1 **PRINCIPAL DIMENSIONS:**

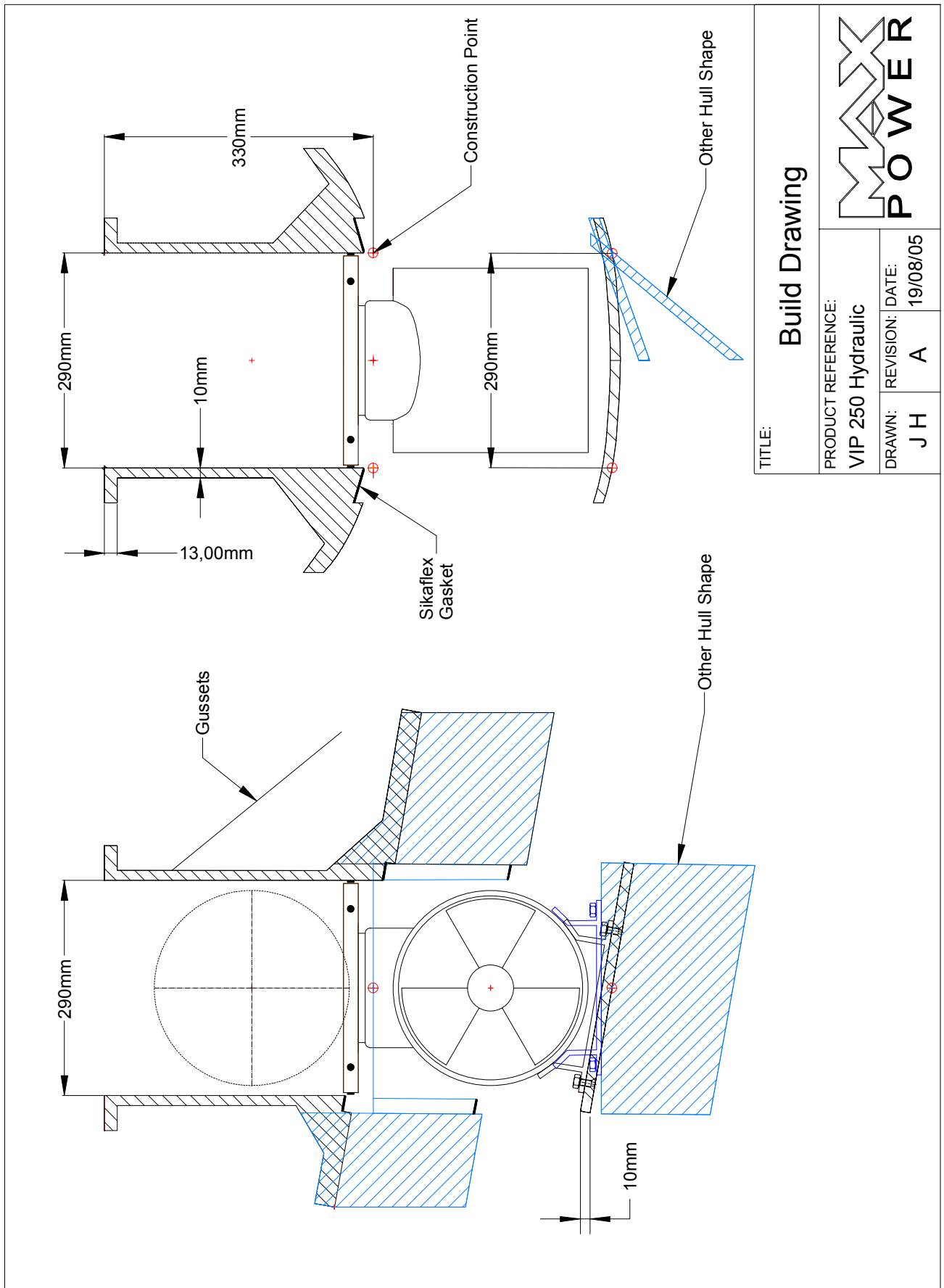

**9.2 – Hydraulic System**

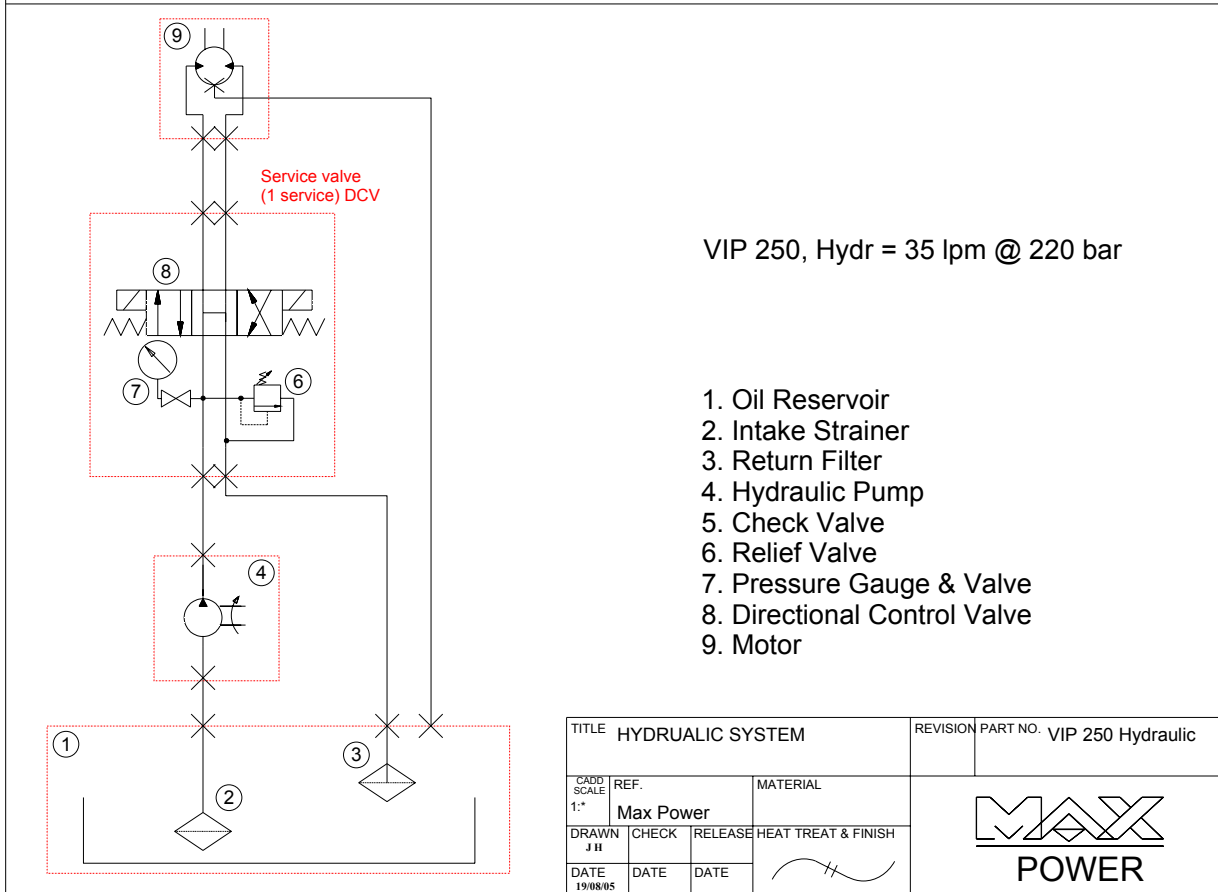
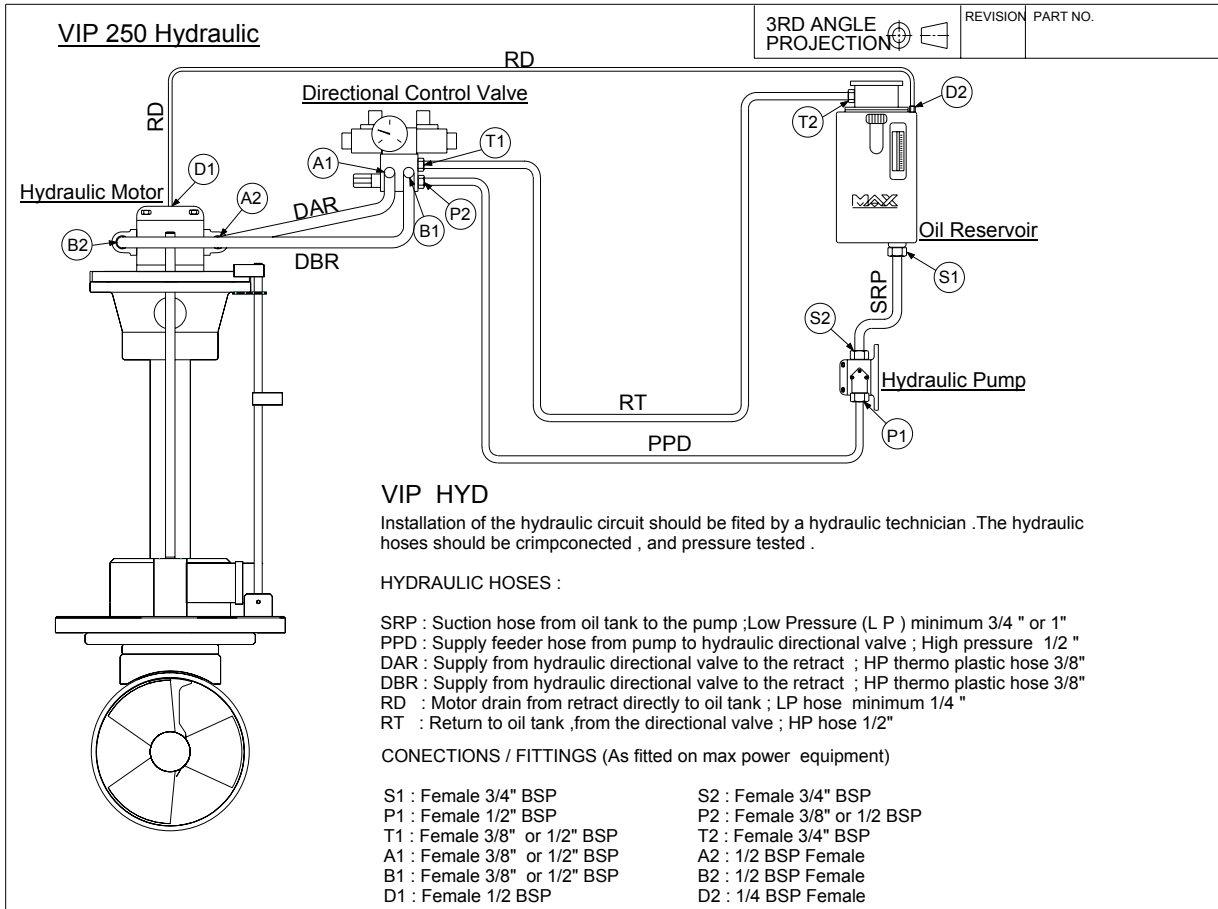

**9.3 – Wiring Diagram**

- 1 - Thruster Battery Bank
- 2 - Fuse & Fuse Holder
- 3 - Manual Battery Isolator
- 4 - Power Relay / Electro Clutch
- 5 - EHP with N/O N/O Heat Sensor
- 6 - Directional Control Valve
- 7 - Up/Down Motors
- 8 - Proximity Switches
- 9 - Electronic Control Card
- 10 - Double Pole Isolator
- 11 - Control Panel

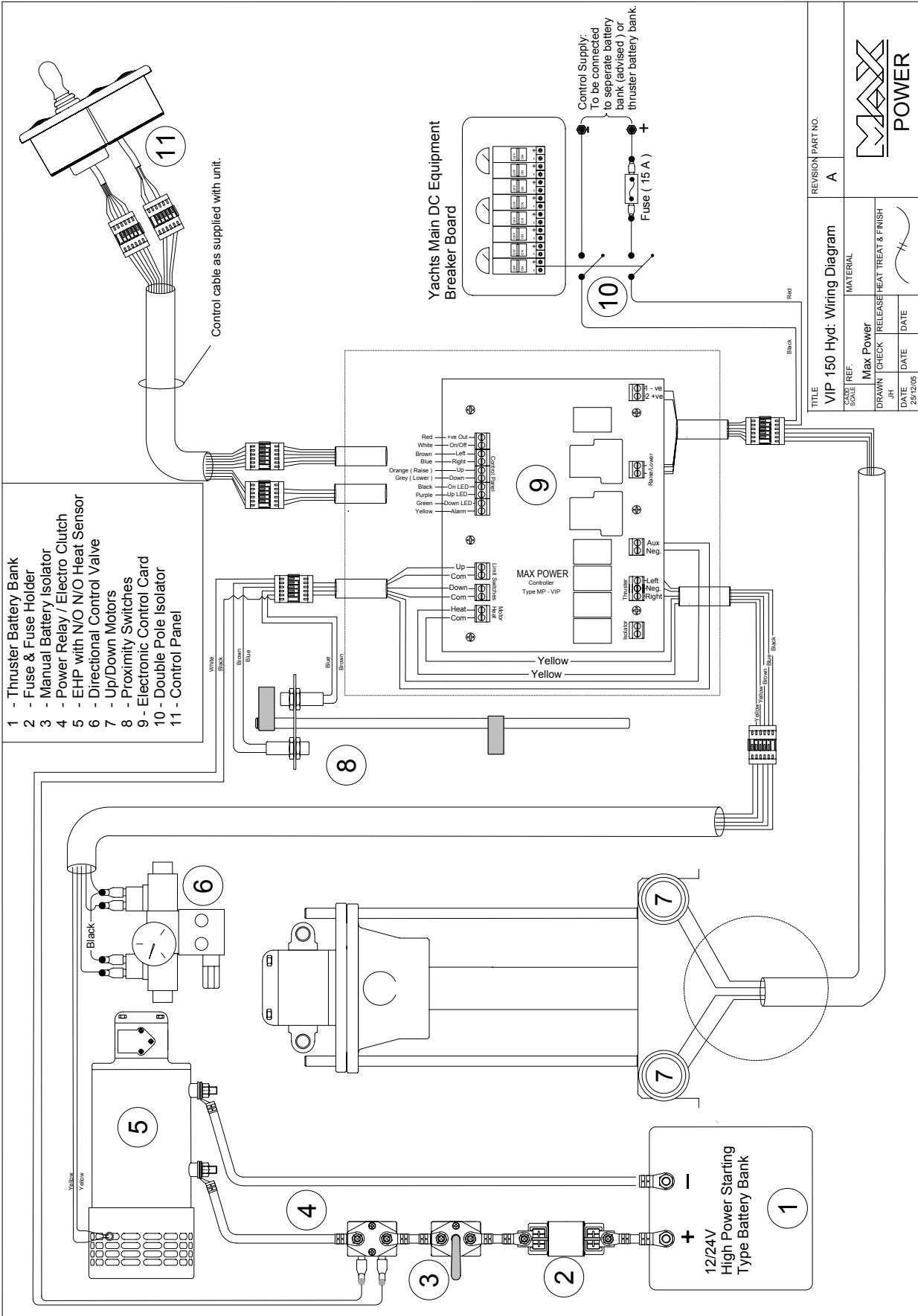

TITLE		VIP 150 Hyd: Wiring Diagram		REVISION PART NO.		A	
SCALE		REF.		MATERIAL		MAX POWER	
DRAWN		CHECK		RELEASE		HEAT TREAT & FINISH	
DATE		DATE		DATE		DATE	
25/12/05							



**POWER**

9.4 ELECTRONIC CONTROL BOX CONNECTIONS:

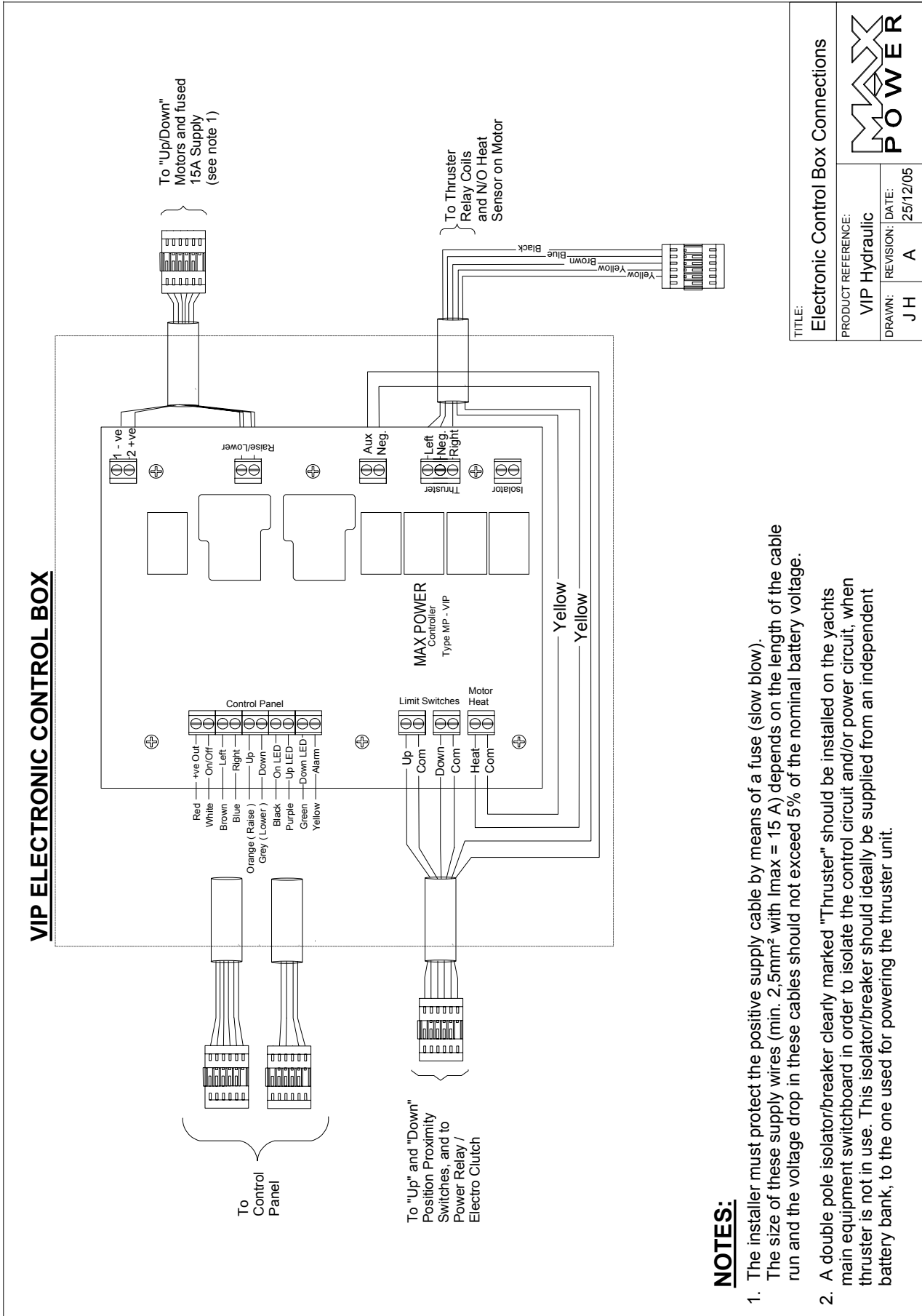

**NOTES:**

1. The installer must protect the positive supply cable by means of a fuse (slow blow). The size of these supply wires (min. 2,5mm<sup>2</sup> with I<sub>max</sub> = 15 A) depends on the length of the cable run and the voltage drop in these cables should not exceed 5% of the nominal battery voltage.
2. A double pole isolator/breaker clearly marked "Thruster" should be installed on the yachts main equipment switchboard in order to isolate the control circuit and/or power circuit, when thruster is not in use. This isolator/breaker should ideally be supplied from an independent battery bank, to the one used for powering the thruster unit.

TITLE: Electronic Control Box Connections	
PRODUCT REFERENCE: VIP Hydraulic	DATE: 25/12/05
DRAWN: JH	
REVISION: A	



**9.5 WIRING LOOM OF MOTOR/RELAY UNIT:**

**Control Panel Installation Guidelines:**

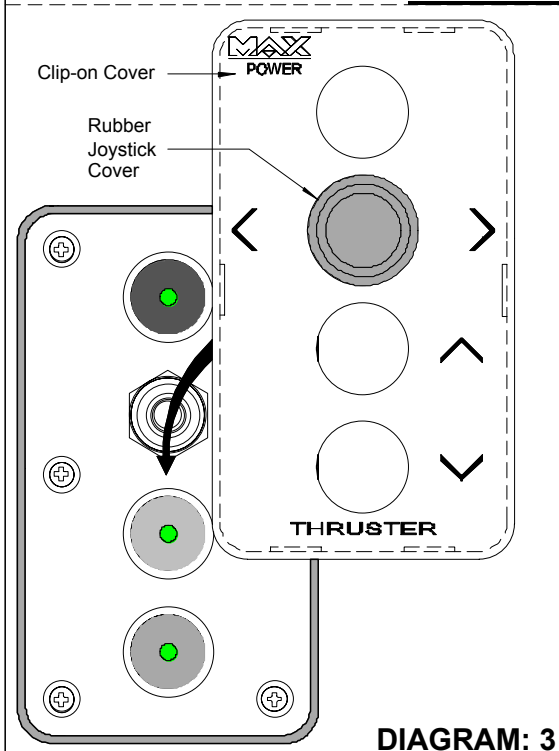
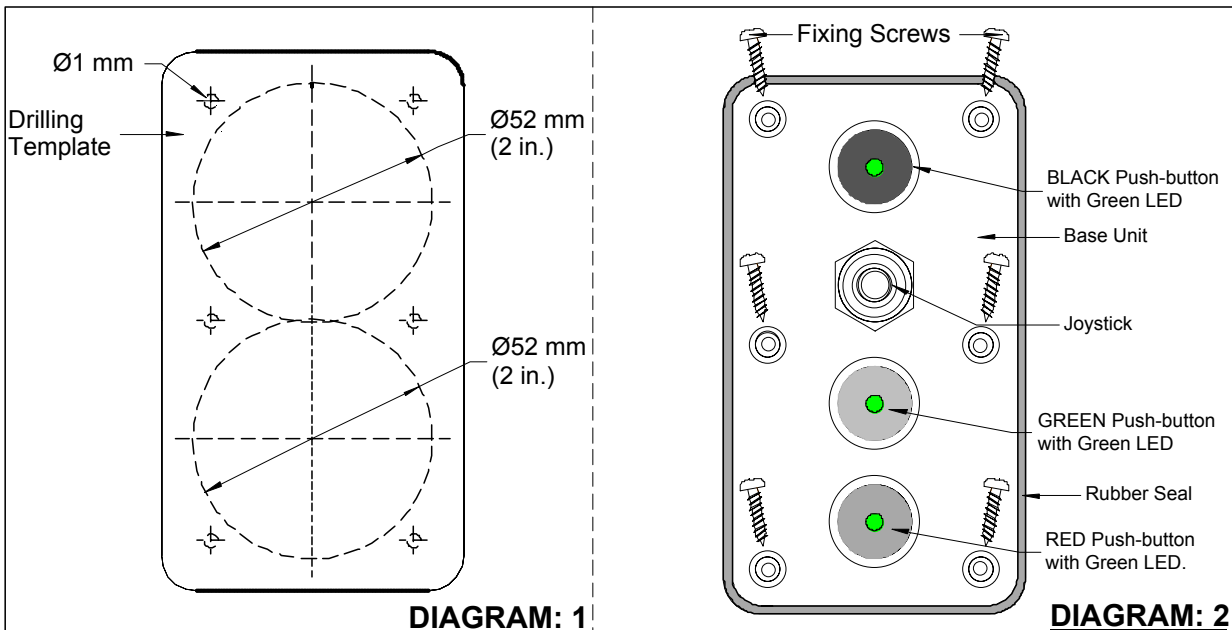

**INSTALLATION GUIDELINES**

Diagram: 1

- 1.1) Stick drilling template in desired mounting position.
- 1.2) Drill the two 52 mm diameter holes using a holesaw.
- 1.3) Place panel in holes and mark the 6 fixing holes.
- 1.4) Remove panel and drill the six 1 mm diameter fixing holes.

Diagram: 2

- 2.1) Make sure that rubber seal is placed on the base column.
- 2.2) Wire and/or plug unit to the control circuit.
- 2.3) Position base so that the joystick is to the top and the "Red" button to the bottom.
- 2.4) Fix base unit with the six fixing screws as supplied with unit.

Diagram: 3

- 3.1) Only when totally finished and satisfied with wiring and positioning of the unit, clip-on the face panel/cover.
- 3.2) Leave rubber joystick cover inserted to clip-on cover when clipping cover into place and push down well once in place.

Diagram: 4

- 4.1) To remove the clip-on cover slide a flat headed screwdriver, with 6 - 7 mm wide tip, between the clip-on cover and the dashboard at position (a), (b) and then (c) and twist the tip slightly. Push in the tip of the screwdriver at least 3 to 4 mm before twisting it.

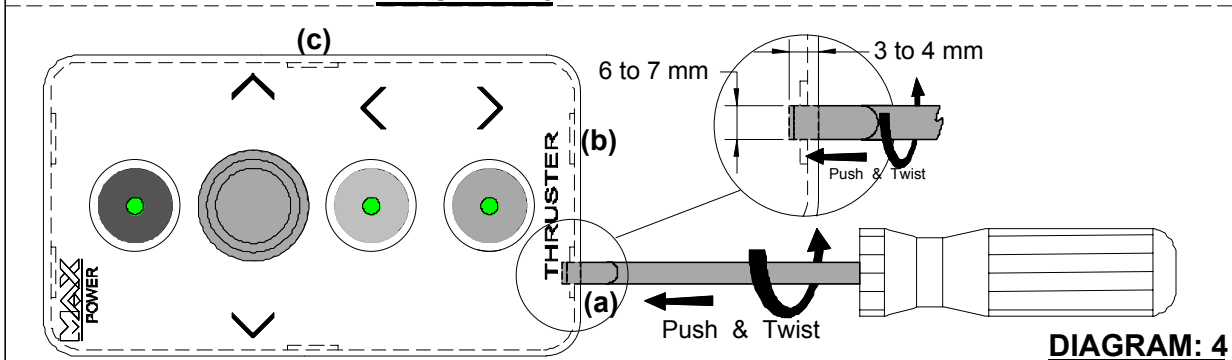



**9.6 – Position Switch Adjustment & Parts List: A**

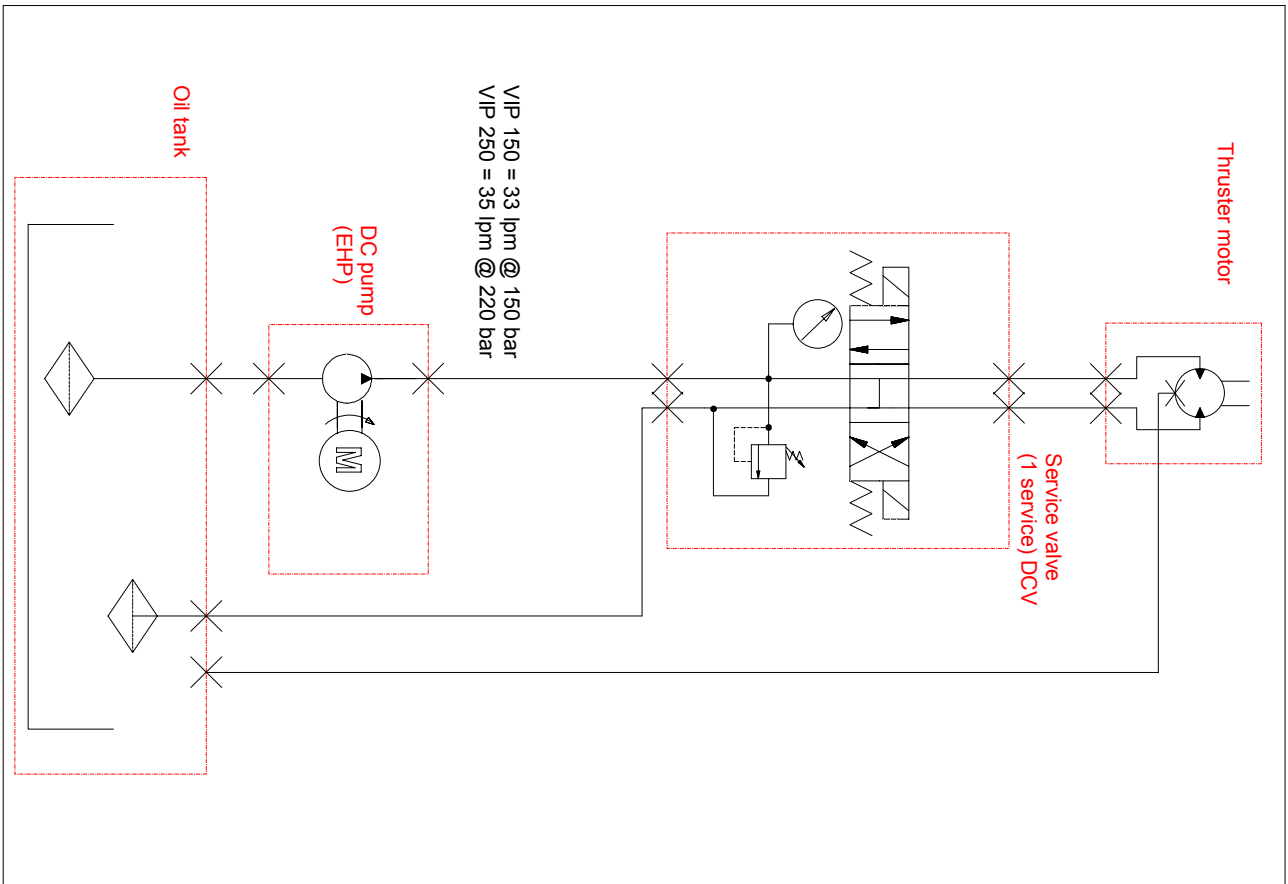

UNLESS OTHERWISE SPECIFIED		TITLE		REVISION PART NO.	
Vip 250 hydraulic		Vip 250 hydraulic		Parts list & ASSY	
SCALE	REF.	MATERIAL			
1"	Max Power				
DRAWN	CHECK	RELEASE	HEAT TREAT & FINISH		
DATE	DATE	DATE			

3RD ANGLE PROJECTION

REVISION PART NO.

No	Description	Quantity	Reference
1	HYDRAULIC MOTOR	1	MPHY6010
3	ADAPTER PLATE	1	MPHY5012
4	FIXING BOLT	5	MPOP4070
5	MOTOR COUPLING	1	MP205027
7	RUBBER COUPLING	1	MP205023
8	LOWER COUPLING	1	MP205025
45	10MM NUT	5	VP084120
88	POSITION DETECTOR	2	OPTI3350

10.1 – Parts Diagram: B

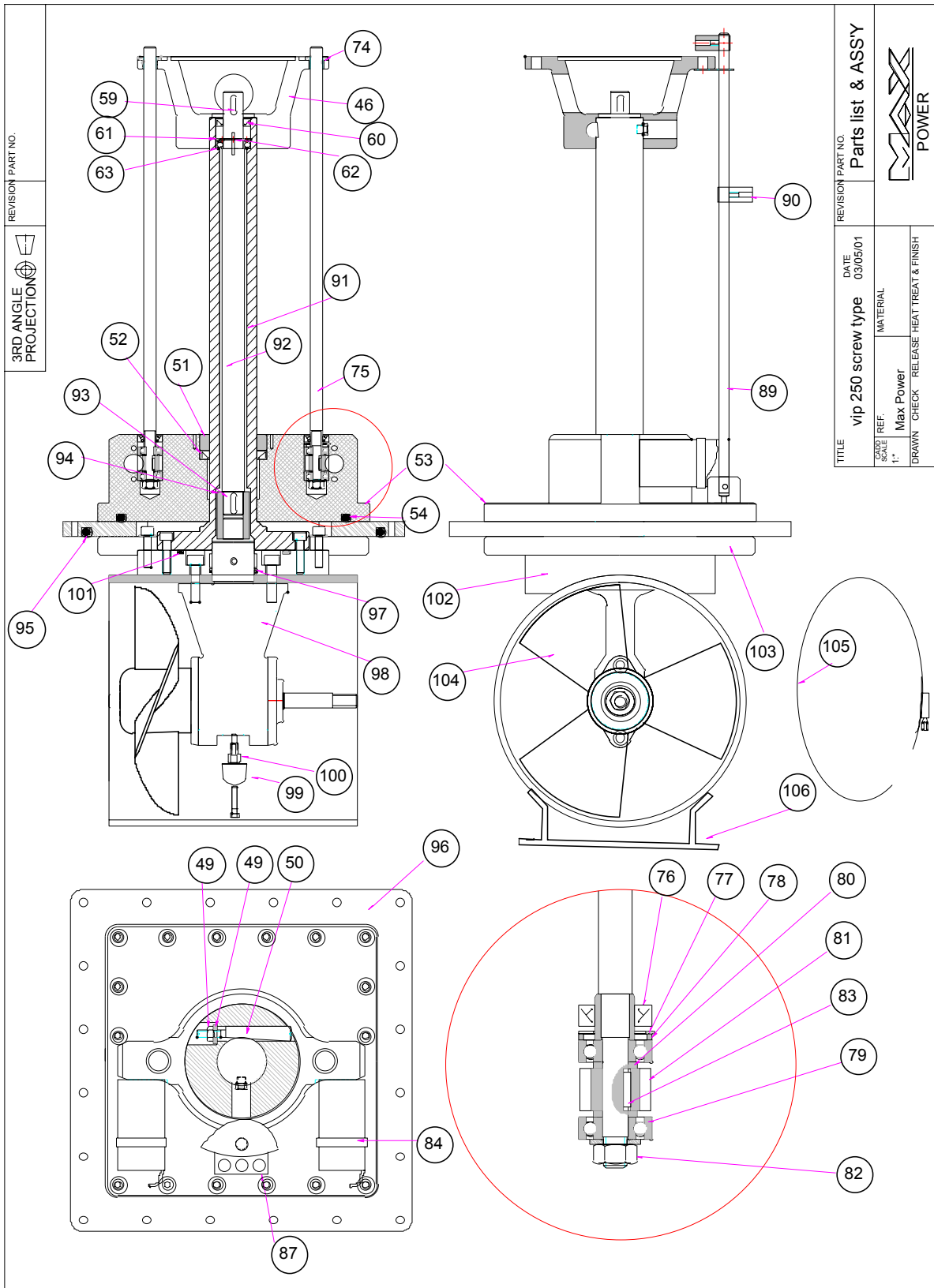

10.2 – Parts List: B

N°	Description	Q	Reference
46	MOTOR SUPPORT	1	VP08 5340
49	MACHINE WASHER	1	VP08 5390
50	COTER PIN	1	VP08 5380
51	WATER GLAND RETAINING RING	1	VP08 5400
52	WATER GLAND	1	VP08 5490
53	SLIDING SHAFT PLATE	1	VP08 5330
54	SHAFT PLATE O RING	1	VP08 5460
59	SHAFT KEY	1	VP08 5420
60	DRIVE SHAFT OIL SEAL	1	VP08 5480
61	CIRCLIP	1	VP08 5500
62	CIRCLIP	1	VP08 5510
63	SHAFT BEARING	1	VP08 5470
74	DRIVE NUT	2	VP08 5004
75	DRIVE SCREW	2	VP08 4042
76	SEAL	2	VP08 5008
77	CIRCLIP	2	VP08 5003
78	END FLOAT SPACER	2	VP08 5005
79	SCREW BEARING	4	VP08 5001
80	WASHER	4	VP08 5007
81	WHEEL	2	VP08 5000
82	NUT 8 MM	2	
83	DRIVE SCREW KEY	2	VP08 5010
84	ELECTRIC MOTOR 12V	2	RT203121
85	ELECTRIC MOTOR 24V	2	RT203122
86	MOTOR SCREW 4MM	4	VP08 4160
87	POSITION SWITCH HOLDER	1	VP08 5620
89	POSITION DETECTOR ROD	1	VP08 5581
90	POSITION DETECTOR	2	VP08 3200
91	SLIDING SHAFT	1	
92	DRIVE SHAFT	1	
93	GRUB SCREW	1	
95	O RING	1	VP08 5460
96	ADAPTER PLATE	1	
97	ADAPTER O RING	1	MP11 2020
98	LEG HOUSING	1	MP11 8030
99	ANODE	1	MPOP5390
100	DRAIN PLUG	1	MPOP5300
101	TUNNEL ADAPTER O RING	1	
102	TUNNEL ADAPTER	1	
103	TORQUE TRANSMISION PLATE	1	
104	PROPELLER D 250	2	MPOP5400
105	TUNNEL CLAMP	2	VP08 5530
106	CLOSING TRAP SUPPORT PLATE	1	VP11 5010

## **WARRANTY COVERAGE :**

The purpose of this document is to set out the terms of warranty cover offered in relation to products purchased by the End User from Max Power or its approved network of resellers. This document will adhere to the following format:-

### **1 DEFINITIONS**

*Authorized Repair Number* – The number given by Max Power on reporting a fault with your thruster

*Dealer* – An authorized Max Power sales centre

*End User* – The boat supplied with supplied equipment and the owner thereof

*Installer* – The authorized centre responsible for the installation of your thruster

*Manufacturer* – supplier of the equipment under warranty

*Pleasure Craft* – Vessels used for owner's personal use that have no commercial use (i.e Charter boats or work boats)

*Resellers* – Max Power approved distributors and dealers

*Serial Number* – Number in upper right hand corner of Warranty document

*Supplier* – The manufacturer (Max Power)

*Warranty* – The terms and conditions that are covered by the manufacturer

### **2 PERIOD OF COVERAGE**

The equipment manufactured by the Supplier is guaranteed to be free from defective workmanship, components and materials under normal usage conditions for a period of two years from the date of purchase by the End User. This warranty is transferable to subsequent owners of this equipment during the period of coverage. If the material is used for anything other than for pleasure craft, the guarantee is limited to a six-month period.

### **3 WARRANTY REGISTRATION**

Register your purchase now to receive free extended warranty coverage. This can be done using one of the following methods (NB. proof of purchase must be included to establish that equipment is still under warranty):

- a) The quickest and easiest method to register your warranty is to fax the attached installation check list and warranty registration to the Max Power (Fax: +33 4 92 19 60 61)
- b) Mail in your warranty registration document, please ensure that you make a copy before sending it. (10 Allée F Coli, 06210 Cannes-Mandelieu, France).

### **4 WARRANTY TERMS**

Year 1 All factory testing, diagnosis, repairs and replacements are performed at no charge to the End User. All parts and up to two hours of labour are covered for repairs and replacements conducted in the field.

Year 2 All factory testing, diagnosis, repairs and replacements are performed at no charge to the End User. This excludes any damage or faults occurring from normal wear and tear on the following items: engine, oil seals, relay contacts (If warranty is registered within the 3 month period following installation), also excluded labour & shipping costs.

## 5 WARRANTY EXCLUSIONS

Damage due to modifications or installation contrary to published specifications  
Cost of hauling the boat  
Damage due to repairs performed by an unauthorized service centre  
Damage due to lack of normal maintenance services  
Damage due to water  
Foreign Object Damage  
Damage due to incorrect installation  
Parts replaced due to normal wear and tear  
Repairs performed without knowledge of manufacturer (please contact dealer to receive Repair Authorization Number)  
Tampering of equipment by the End User  
Cost of travel to and from the job site  
Cost of economic loss, including injury to any person, damage to property, loss of income or profit, communication, lodging, inconvenience  
Consequential damage due to failure, including those arising from collision with other vessels or objects

## 6 PROCEDURAL GUIDELINES

PLEASE VIEW THE TROUBLE SHOOTING LIST TO ASCERTAIN OR SOLVE ORIGIN OF PROBLEM PRIOR TO CONTACTING THE DEALER/INSTALLER

- 1) Contact your dealer/installer to report the problem.
  - a) If you do not know who this is, contact the nearest Max Power distributor.
  - b) If you are in foreign waters please contact the nearest Max Power distributor.
- 2) Ensure you have the serial number and model number of your thrusters unit at hand.
- 3) Dealer/Installer will come to site to decipher the cause of the fault.
- 4) If the cause of fault is due to a manufacturing problem the dealer will contact Max Power to receive Repair Authorization Number.
- 5) If the problem is due to an installation error please contact your installer.

**DISTRIBUTER CONTACT LIST:****SOUTHERN EUROPE:**

<b><u>CYPRUS</u></b> OCEAN MARINE EQUIPMENT LTD Limassol Tel: + 357 53 69 731 Fax: + 357 53 52 976 Email: <a href="mailto:oceanm@spidernet.com.cy">oceanm@spidernet.com.cy</a>	<b><u>CYPRUS</u></b> TUTI MARE TRADING Limassol Tel: + 357 25 431 313 Fax: + 357 25 431 300 Email: <a href="mailto:tutimare@cytanet.com.cy">tutimare@cytanet.com.cy</a>
<b><u>FRANCE</u></b> ACCASTILLAGE BERNARD Cannes La Bocca Tel: + 33 493 90 47 47 Fax: + +33 5 46 45 49 53 Email: <a href="mailto:t.barrez@accastillage-bernard.fr">t.barrez@accastillage-bernard.fr</a>	<b><u>GREECE</u></b> ALEX MARINE Piraeus Tel +30 10 41 29 539 Fax: + 30 10 41 12 932 Email: <a href="mailto:alexmarine@otenet.gr">alexmarine@otenet.gr</a>
<b><u>ITALY</u></b> SIEMENS VDO Trading Srl. Novate Milanese(MI) Tel: + 39 0235 6801 Fax: + 39 0238 204 339 Email: <a href="mailto:piergiorgio.allaria@siemens.com">piergiorgio.allaria@siemens.com</a>	<b><u>PORTUGAL</u></b> PLASTIMO PORTUGAL (SIROCO) Lisbon Tel: + 351 21 362 04 57 Fax: + 351 21 362 29 08 Email: <a href="mailto:plastimo@siroco-nautica.pt">plastimo@siroco-nautica.pt</a>
<b><u>SPAIN</u></b> ACASTIMAR Cambrils Tarragona Tel: + 349 77 36 2118/9074 Fax: + 349 77 36 2687 Email: <a href="mailto:acastimar@acastimar.com">acastimar@acastimar.com</a>	<b><u>TURKEY</u></b> EGEMAR Tuzla - Istanbul Tel:+90 216 494 21 68 Fax:+90 216 494 22 18 Email: <a href="mailto:sales@egemar.com">sales@egemar.com</a>
<b><u>CROATIA</u></b> ANORTI ADRIA Mirosevecka c 122, Zagreb Tel: +385 98 1896 770 Fax: +385 23 386 075 Email: <a href="mailto:info@anortiadria.hr">info@anortiadria.hr</a>	<b><u>SLOVENIA</u></b> ANORTI Kavciceva 66 Ljubljana Tel: +386 1 544 6436 Fax: +386 1 544 6435 Email: <a href="mailto:info@anorti.si">info@anorti.si</a>
<b><u>MALTA</u></b> STRAND MARINE Triq Is Sebh, Qormi Tel: +356 21 472 336 Fax: +356 21 472 338 Email: <a href="mailto:info@strandmarinemalta.com">info@strandmarinemalta.com</a>	

**NORTHERN EUROPE:**

<b><u>DENMARK</u></b> PALBY MARINE Vejle Tel: + 45 75 88 13 11 Fax: + 45 75 88 17 01 Email: <a href="mailto:palby@palby.dk">palby@palby.dk</a>	<b><u>GERMANY</u></b> LEAB Schlieswig, Busdorf Tel.: +49 4621- 36 06 67 Fax: +49 4621- 36 06 69 Email: <a href="mailto:info@leab.de">info@leab.de</a>
<b><u>ICELAND</u></b> VELASALAN 101 Reyjavik Tel : +354 580 5312 Fax : +354 580 5301 Email: <a href="mailto:Stefan@velasalan.i">Stefan@velasalan.i</a>	<b><u>HOLLAND &amp; BELGUIM</u></b> NAVIMO HOLLAND Schoonhoven Tel: +31 182 320 522 Fax: +31 182 320 519 Email: <a href="mailto:info@plastimo.nl">info@plastimo.nl</a>
<b><u>FINLAND</u></b> MASTERVOLT FINLAND Raisio Tel: + 358 2 4339990 Fax: + 358 2 4350085 Email: <a href="mailto:info@mastervolt.fi">info@mastervolt.fi</a>	<b><u>HOLLAND</u></b> KEMPER EN VAN TWIST Dordrecht Tel: + 31 078 61 30 155 Fax: + 31 078 61 36 746 Email: <a href="mailto:cscheepbouwer@kvt.nl">cscheepbouwer@kvt.nl</a>

<p><b><u>NORWAY</u></b>  PROGRESS INGENIORFIRMA AS  Kjeisaas  Tel: + 47 22 02 79 00  Fax: + 47 22 02 79 01  Email: <a href="mailto:thomas@progressing.no">thomas@progressing.no</a></p>	<p><b><u>SWEDEN</u></b>  PLASTIMO NORDIC  Henan  Tel: + 46 304 360 60  Fax: + 46 304 307 43  Email: <a href="mailto:mikael.andersson@navimo.se">mikael.andersson@navimo.se</a></p>
<p><b><u>U.K</u></b>  PLASTIMO UK  Eastleigh, Hampshire  Tel: + 44 870 751 4666  Fax: + 44 870 751 1950  Email: <a href="mailto:sales@plastimo.co.uk">sales@plastimo.co.uk</a></p>	<p><b><u>U.K.</u></b>  AR PEACHMENT  Norfolk  Tel: + 44 1603 714 077  Fax: + 44 1603 714 211  Email: <a href="mailto:kevin@peachment.co.uk">kevin@peachment.co.uk</a></p>

**AMERICAS :**

<p><b><u>ARGENTINA</u></b>  BARON SRL  Buenos Aires  Tel: + 54 11 4580 55 56  Fax: + 54 11 47 46 16 96  Email: <a href="mailto:Admin@baron.com.ar">Admin@baron.com.ar</a></p>	<p><b><u>CANADA</u></b>  REKORD MARINE ENTERPRISES LTD  Vancouver  Tel: + 1604 325 52 33  Fax: + 1604 325 03 26  Email: <a href="mailto:michael@rekord-marine.com">michael@rekord-marine.com</a></p>
<p><b><u>BRAZIL</u></b>  SAILING PRODUCTS  Rio de Janeiro  Tel: + 55 21 494 7222  Fax: + 55 21 494 7223  Email: <a href="mailto:spsail@ibm.net">spsail@ibm.net</a></p>	<p><b><u>U.S.A.</u></b>  SCANDVIK  Vero Beach, Florida  Tel: + 1 561 567 28 77  Fax: + 1 561 567 91 13  Email: <a href="mailto:sales@scandvik.com">sales@scandvik.com</a></p>

**AUSTRALIA & SOUTH EAST ASIA:**

<p><b><u>AUSTRALIA</u></b>  OCEANTALK  Sydney  Tel: + 612 9981 9500  Fax: + 612 9981 9555  Email: <a href="mailto:rk@oceantalk.com.au">rk@oceantalk.com.au</a></p>	<p><b><u>NEW ZEALAND</u></b>  POWER &amp; MARINE  Wiri Auckland  Tel: + 64 9 914 55 55  Fax: + 64 9 914 55 88  Email: <a href="mailto:sales.staff@powermarine.co.nz">sales.staff@powermarine.co.nz</a></p>
<p><b><u>CHINA</u></b>  RONSIL DEVELOPMENT  Hong Kong  Tel: + 852 2834 1633  Fax: + 852 2834 0201  Email: <a href="mailto:ronsil@netnavigator.com">ronsil@netnavigator.com</a></p>	<p><b><u>CHINA</u></b>  HOLYLIGHT TRADING  Hong Kong  Tel: + 852 2543 7048  Fax: + 852 2543 6156  Email: <a href="mailto:coha@biznetvigator.com">coha@biznetvigator.com</a></p>
<p><b><u>JAPAN</u></b>  KAZ MARINE  Yamato City, Kanagawa  Tel: +81 46 268 41 01  Fax: +81 46 268 4351  Email: <a href="mailto:kazplast@olive.ocn.ne.jp">kazplast@olive.ocn.ne.jp</a></p>	<p><b><u>SINGAPORE</u></b>  OCEANTALK ASIA  Singapore  Tel: + 65 6543 4041  Fax: + 65 6543 4042  Email: <a href="mailto:lee@oceantalk.com.sg">lee@oceantalk.com.sg</a></p>

**MIDDLE EAST & AFRICA**

<p><b><u>ISRAEL</u></b>  YAMIT  PO Box 6158  Tel Aviv  Tel: + 972 3 527 1779  Fax: + 972 3 527 1031  Email: <a href="mailto:office@yamit.co.il">office@yamit.co.il</a></p>	<p><b><u>SOUTH AFRICA</u></b>  MANEX &amp; POWER  5 Industry Street  Paarden Eiland  Tel: + 27 21 511 72 92  Fax: + 27 21 510 14 89  Email: <a href="mailto:manex@manex.co.za">manex@manex.co.za</a></p>
--	--



Serial N°:

**WARRANTY FORM**

VERY IMPORTANT

Please complete this form and fax a *COPY* to Max Power with a copy of the installation invoice or the invoice of the yacht/boat in order for the warranty to come into effect.

**To Be Completed by Owner:**

Name of Owner:..... Contact No. :.....  
 Address: ..... E-mail: .....  
 Country:.....Postcode: .....  
 Name of Skipper:..... Contact No. :.....  
 Signature of Owner: ..... Date: .....

**To Be Completed by Installer:**

**Installation Details:**

Thruster Model :..... Electric/Hydraulic :.....  
 Date of Installation :..... Date of Launching Boat : .....  
 Type and model of Boat : ..... Builder:..... Build Year: .....  
 Pleasure or Commercial craft?:..... Sail or Motor: ..... Rig:.....  
 Navigates at Sea or River or Canals?..... Hull construction material :.....  
 L.O.A. :.....L.W.L. :..... Beam :..... Free Board:.....  
 Displacement Weight at Full Load: :..... Height & Length of Superstructure:.....  
 Tunnel Diameter, Thickness, Material & Length: .....  
 If Electric, Battery Type, Size & Number: .....

**Installation Checks:**

	Before Operating Thruster	While Operating Thruster
<u>Electrical:</u> Voltage at Batteries	.....	.....
Voltage at Thruster Motor	.....	.....
Charge at Alternator in Amps	.....	.....
Ampere in Motor Power Circuit	.....	.....
<u>Mechanical:</u> Verify if drive coupling between motor and drive leg is correctly tightened:..Yes / No		
Verify if all cable connections is sufficiently tightened:.....Yes / No		
If hydraulic verify all hydraulic connections: .....Yes / No		

Thruster installation tested and working correctly: .....Yes / No

Important: Refer to installation manual for full installation details.

Name of Installer: ..... Signature:.....

PLEASE RETURN BY FAX: + 33 4 92 19 60 61  
 TO GAIN YOUR EXTRA WARRANTY COVERAGE