



MANUAL

MAX POWER RETRACT R300

FOR _____

BUILT BY _____

DELIVERED _____

***A copy of this manual must remain
on board for consultation.***

I. INTRODUCTION

A AFTER SALES SERVICE

ADDRESS MAX POWER
Via Philips 5, 20900 Monza (MI), Italy

TEL + 39 039 200 1973-936
FAX + 39 039 2004299

RETRACT SERIAL N° S . R315 / R321

IMPORTANT GENERAL INFORMATION

With a constant concern of improving our products, we reserve the right to make changes to this manual without prior notification.

All statistics and explanations within this manual were believed to be correct at the time of printing.

Each RETRACT installation requires a preliminary study of performance and feasibility.

This study covers 4 distinct sub systems

1. The RETRACT thruster unit
2. Hydraulic equipment
3. Electrical control system
4. Electrical Power system if fitted with Electro pump

CHECK LIST FOR THE PROJECT MANAGER

It is very important to carefully read the entire manual before starting the installation.

At the end of the manual, you will find a MAJOR POINT CHECKLIST when you are inspecting the work of your installers. All the points listed must be strictly respected for the proper and safe operation of the RETRACT system.

The RETRACT should be installed by a professional specializing in this type of installation.

Architects, construction shipyards and surveyors should be contacted before installation.

All official bodies or classification experts should be contacted before the installation.

All mechanical installation must apply with the conditions as laid down in the country of the boats registration.

All electrical installation must apply with the conditions as laid down in the country of the boats registration origin.

All hydraulic installation must apply with the conditions as laid down in the country of the boats registration origin.

POSITIONING OF THE RETRACT UNIT

IMPORTANT Correct positioning is essential for correct operation.

The difference between the centre of gravity of the submerged surfaces and the centre of gravity of the surfaces exposed to side wind forces results in a rotational torque.

One of the bow thruster's primary functions is to neutralize this torque.

Therefore the distance between the thruster and the yachts extremities must be as LONG as possible.

See installation drawing

The following considerations are essential when determining the position of the RETRACT.

The top of the turbine must be 300 mm below the water line when fully extended. In other words the turbine should be at least one full diameter below the water line. The mounting-flange should be parallel with the bottom of the hull.
the structural compatibility of the mounting base,
the access needed for installation, and removal of unit,

IMPORTANT make sure that there is enough room to allow for complete removal of the RETRACT unit, and room for the connection of the hydraulic piping, either by the direct coupling of the flexible hoses or by the use of metallic elbow connections.

sufficient access for all maintenance procedures must be allowed for.

NOTE Always make sure that there is enough room for the manual override system.

See drawing

To install a RETRACT in the stern, make sure that the turbine flow is clear of all obstacles, or select the best possible compromise.

INSTALLATION OF THE RETRACT UNIT

CONSTRUCTION OF THE MOUNTING BASE

MAX POWER can supply as an option, a G.R.P. laminated mounting base, or an aluminium machined mounting-flange. These options allow you to save considerable installation time, and assure precise installation.

The general method and materials used must be adapted to the particular hull material (laminated wood, GRP, sandwich, aluminum, or steel). Naval Architects, Classification Societies or engineering firms should be consulted.

The thruster's mechanical stresses are spread over the hull by the mounting base. Installation, which should be executed by welding or bonding to the hulls plating, normally reinforces the hull, The mounting base may be attached to frames and stringers as well.

After the mounting base has been made and fitted the RETRACT should be temporarily secured on the flange to check its height its, centering, the accessibility of fittings and the ease of operation for manual override system.

GRP HULLS

The mounting base may be molded into the hull during construction or prefabricated, and then laminated onto the hull later.

METAL HULLS

The mounting base may be constructed with the hull or prefabricated, and then welded onto the hull later.

IMPORTANT In both cases, the top surface of the mounting base (or the flange) must be given particular attention and machined perfectly flat in order to accept the O ring seal of the RETRACT base flange and ensure perfect water tightness.

The bolts fixing the RETRACT onto the mounting flange must be inserted from top to bottom. Provide sufficient access underneath the flange to allow for tightening the nuts.

If the access is not possible, provide a special mounting flange with metric 10 mm studs or tapped holes.

CONSTRUCTION OF HULL OPENING & CLOSING PLATE

The required hull opening dimensions are $L = 350 \text{ mm} \times W = 260 \text{ mm}$.

The longitudinal centre line of the opening coincides with that of the mounting flange But the transversal centre line of the opening is offset by 27 mm to the rear with respect to the transversal centre line of the mounting flange.

The opening is closed by a plate which may be made from the cut-out hull section, or specially fabricated.

This closing plate should bear against a flexible seal fixed to a 30-mm wide rebate. While the hull opening closing plate is being made, the RETRACT must be temporarily secured on the mounting base flange to facilitate correct closing plate fabrication.

The hull plate must be fixed to the supplied aluminum adjustable mounting (which has 4 elongated holes for initial adjustment).
the gasket in the hulls rebate can be made either out off soft cellular neoprene rubber or moulded in **soft** SIKAFLEX (or a similar product) to form a flexible seal .Precaution must be taken to ensure that the flexible gasket does not glue the closing plate to the hull while drying .The plate must rest evenly, on the gasket with a reasonable pressure.

IMPORTANT To prevent marine growth inside the casing, it is essential that once the unit is raised, no light is allowed to enter. Therefore the closing plate gasket is **essential** and requires careful and permanent fixation.

FINAL FITTING OF THE RETRACT UNIT TO THE MOUNTING BASE

CAUTION To ensure absolute cleanliness, hydraulic lines and ports must remain plugged until connection to hydraulic system .

Final installation on the mounting base must be made after thoroughly cleaning and then liberally coating both joining surfaces (case and base) with a good quality marine grease. This is so that the O ring seal is compressed flat, evenly, smoothly and squarely when the bolts are tightened.

Under no circumstances should the RETRACT be glued or bedded down with a marine type mastic/glue such as sikaflex or other similar product.

The flange bolt should be **tightened sequentially** and in successive passes until the two surfaces touch. If desired, a torque wrench can be used and the bolts can be tightened to a torque of 4,0 kg/M. The flange bolts should be metric size 10 mm of stainless steel, and should have a large stainless steel washer placed above a nylon washer. The nylon washers avoid stainless steel contact with the aluminum case. The nuts should be type NYLOCK.

The 2 lifting lugs provided by MAX POWER, should be put in a small plastic bag, along with the hydraulic pipe plugs, for storage and future use by the ships crew or owner.

FINAL ADJUSTING OF THE CLOSING PLATE (see drawing)

Once the thruster is permanently bolted onto the mounting base and has been correctly tightened, reinstall the plate and check it's adjustment.

When testing the cover plate fit, either use the manual raising lever or the raise/lower unit.

When the upper travel limit has been reached, the mechanical locking device, which consists of the locking cam (b) and the locking lever (c) must engage automatically.

Although the RETRACT R300 is delivered completely tested and folded in the UP position, the locking lever can not be definitively adjusted at the factory. The locking lever adjustment eccentric (e) has been set at the factory in the medium position.

The adjustment procedure is as follows.

Adjust the hull closing plate by performing several up down maneuvers using the elongated holes in the aluminum mounting plate to make initial adjustment.

Tighten the bolts holding the aluminum mounting **using locktite** .

Remove the retaining screw (f) on the plastic bush

Place the manual raising lever (a) on the end of the lifting arm and press down to raise the arm (turbine) to maximum height. while holding the manual lifting arm a second person can rotate the eccentric (e) right or left, to raise or lower the locking lever to the position required

Replace the bush retaining screw in the nearest convenient hole (two holes provided)

Should the turbine still have some movement when locked increase the locking bolt height using the eccentric by one half hole.

Should **at this point** the thruster only just, not quite lock, then the locking pressure can be **very slightly** increased using the pressure limiter on the up down unit. The locking pressure should not exceed 50 bar .

This entire procedure is only possible when the **soft flexible** gasket is correctly and permanently installed.

UPIDOWN UNIT INSTALLATION

The raise/lower unit should be near the RETRACT unit. It should be installed in an readily accessible and dry place.

The hydraulic ports (LA and LB) on the raise/lower pump unit and the raise/lower ram (VA and VB) must be connected A to A and B to B.

These flexible hoses must be 3/16" or 1/4 " with an operating pressure rating of at least 100 bar.

CAUTION to prevent the risk of electrical earth leakage's, the hydraulic hoses connected directly to the RETRACT should be non-conductive (non-metal braided

hose) high pressure thermoplastic hose. Absolute internal cleanliness is essential. After pipes and hoses have been equipped with their fittings, they must be blown out with compressed air, then plugged until connected.

A parachute valve is installed in the B port in the up/down unit and this is very easily blocked by contamination!

Should during closing plate adjustment or thruster operation the up down unit motor ceases to function check the up down unit fuse (16 A).

The up down unit pressure limiter is normally **pre set**, should you need to re adjust it **slightly** do not forget that the up down unit **functions constantly** on maximum pressure while the thruster is thrusting. This to hold the turbine in the down position.

TRANSMISSION LUBE OIL TANK INSTALLATION

Retract thrusters are no longer equipped with transmission lub oil tanks.

HYDRAULIC POWER SYSTEM INSTALLATION

All the hydraulic power equipment, such as the piping, reservoir, pump, directional valve, etc. should be installed in compliance with the usual rules of accessibility to enable periodic checks and maintenance.

PRESSURE PIPING

All hydraulic high pressure power circuit piping must comply with high pressure standards, and have a diameter at least equal to that recommended (see diagram) in order to reduce pressure loss especially when the installation's layout requires long hose lines.

All power circuit piping must have a continuous service pressure rating of at least 280 bar. Fittings must be of good quality, and crimped as per manufacturer instructions.

All power circuit piping connected directly to the thruster unit must be of non conductive thermo-plastic type.

The following rules must be taken into account when positioning the hydraulic power components.

Flexible hydraulic hoses must not have a bend radius less than the manufacturers stated minimum. Also the larger the bend the higher the efficiency of the system. Small radius metallic elbow fittings must be avoided on the pressure piping.

The pump intake hose line (from the reservoir) must be of a quality that is not subject to pinching crimping or collapse.

This hose should preferably be shorter than 2 meters and have no more than two 90-degree elbows bends.

OIL RESERVOIR

The reservoir should be mounted as close to the pump as possible and must always be higher than any other component in the system. The reservoir must be mounted at a height that allows the breather to be situated 500 mm, (18 ") or higher, above the waterline. If this is not possible, then the breather can be removed and installed on the end of an extension pipe or hose.

Mounting the reservoir too low could result in oil draining back, or overflowing the tank. Be sure to allow enough space above the reservoir to service the filter.

If MAX POWER does not supply the reservoir, then provide a return filter of 60 microns and a suction strainer.

CAUTION the oil tank must be installed above the pump so as to gravity feed to the pump.

The thrusters' motor case drain must return directly to the top of the tank. With no filters check valves or other drain lines connected to it. Backpressure on the RD (drain line) will cause damage to the hydraulic motor.

The reservoir must be flushed after installation.

DIRECTIONAL CONTROL VALVE BLOCK

The directional control valve (DCV) must be placed between the pump and the RETRACT unit. it is recommended to locate the DCV as near to the RETRACT as possible (in an accessible and dry place) it is preferable for maintenance reasons that the unit is mounted horizontally. The valve block is fitted with a pressure relief valve that has been factory tested and set to your thruster's maximum pressure.

ELECTRO HYDRAULIC PUMP (EHP) INSTALLATION

The Electro hydraulic pump should be as **close as possible to the batteries** to reduce voltage drop in the electrical lines.

Other important considerations in EHP installation are

- Sufficient cooling air available to the motor
- Proper maintenance access
- A dry well ventilated position
- Secure fixation support and straps to prevent movement in any sea condition

Hydraulic pumps must never be allowed to run dry, not even for a few seconds, prime circuit before start up.

MECHANICAL DRIVEN HYDRAULIC PUMP (MDP) INSTALATION

The pump/clutch assembly (PCA) may or may not be supplied by MAX POWER. However the following general rules apply to all types of pump/clutch installations.

If MAX POWER supplies the assembly, additional documentation will be supplied.

In order to prevent pump damage, always pay particular attention to the pump's designed rotation direction.

Some pumps have drain lines, these must be connected directly to the **bottom** of the reservoir.

NOTE when installing a hydraulic pump driven directly by generator set, provide a device for shedding the vessel's electrical mains network. Control box terminals N° 21 negative and N° 22 positive give a signal that can be used for this purpose.

FILLING THE HYDRAULIC CUIRCIT

MAX POWER recommends the use of ISO GRADE 15 to 32 hydraulic oils for the power circuit. This mineral oil has already been used by Max Power during the run in tests and consequently the RETRACT motor and piping are already filled with this kind off oil.

CAUTION Biodegradable and mineral (commonly used) oils are non-compatible and should not be mixed or used together. Mixing them will deteriorate certain hydraulic elements. If you intend to use a biodegradable oil, thoroughly flush the existing mineral oil from the RETRACT unit first with the appropriate oil.

CONTROL SYSTEM INSTALATION

Although MAX POWER has used the best materials available, the installer should endeavor to install all electrical equipment with the view that it should be in a ventilated and dry environment at all times. Control panels mounted at helm stations must be provided with watertight protection if the station is exposed to the weather.

All wiring must be insulated from ground and its installation executed in compliance with safety and classification standards.

CONTROLL SYSTEM

The Retract R300 control system is all centralized in the electronic control box
All numbers indicated on our diagrams must be connected 1 to 1 and 2 to 2 ,wire sections must be respected to the letter .

All Retract equipment is connected to this box

All wires should be carefully **labeled to reduce the chance of error** and simplify checking and troubleshooting.

All wire ends for terminals should be tinned before inserting into terminal blocks.

The control system of the RETRACT requires 30 amps of stabilized 24 VDC power. If you are installing an EHP system you must use a **different battery supply** than that used for the EHP power.

The 24 volt input power is automatically transformed to produce 12 volts for the control panel use **control panel only** .

The major power consuming components of the RETRACTS electrical system (the raise/lower unit, the directional valve solenoids, and the electromagnetic clutch, or power relays if EHP) are supplied with 24 volts from the control box.

Switching the thruster system on is achieved by a two-pole 32-amp circuit breaker (not supplied by Max Power) which should normally be located on the main electrical panel.

Power system wiring (EHP only)

The same criteria's as mentioned above applies. The electrical power cables must be off a sufficient size (see diagram) and should be connected directly from the batteries to the fuse ,main breaker, the power relays and finally the EHP.

There should be **no other equipment** or connections in the circuit. (Use conductive grease on the cable connections)

Cables that are specified larger than is possible to fit into the terminal blocks should be thinned back and tinned to fit. They should not be forced into the terminal blocks.

Note : the Electro-pump does not have a specific polarity.

The supply cable diameter (area section) should be sufficient so that the voltage drop between battery and motor is no greater than 2 volts for a 24 volts supply.

Always make your cable runs as short as possible

The most commonly found errors on EHP installations are voltage drop related Excessive voltage drop will cause, **low performance, over heating ,and unreliability of power relays .**

Optional equipment

An extra relay can be added on the negative battery wire and is controlled by terminals 31 & 32 (same as the positive relay). This option is highly recommended in aluminum , steel ,carbon fibber hulled vessels.

CHECKS, TESTS & ADJUSTEMENTS

BEFORE LAUNCHING

IMPORTANT: Before the launch, verify that the RETRACT unit inspection top plate has been replaced (if it was removed during installation) and that all the lower flange bolts have been tightened. Torque for all these bolts is 5 kg/m.

IMPORTANT: The cathodic protection system on board must provide sufficient protection to the aluminium body of the RETRACT unit against galvanic corrosion or electrolysis. The RETRACT unit must be grounded by connecting a bonding wire to the main cathodic protection system.

Before carrying out the below test we recommend to disconnect the wire at terminal N° 32 in the control box.

- Check all fittings for tightness and leaks.
- The transmission is already filled with oil at the time of delivery.
- Max Power uses HYPIOD HD 80W/90 oil in the transmission, therefore, fill the transmission lube oil header tank with a similar grade oil. The function of this lubricant tank is to ensure a constant pressure, as well as a visual control of the oil-level. The tank should be filled to the $\frac{3}{4}$ level. Purge air in tube before fitting the pipe to the RETRACT.
Perform UP / DOWN tests (standard joystick control panel).
- Check UP / DOWN operation.
- The up down unit has a second function; it blocks the turbine in the down position when thrust is applied.
Move joystick to port or starboard and check that the up/down hydraulic pump is pulling the turbine down.

AFTER LAUNCHING

Check for water leaks.

Switch on the system power at the breaker and repeat the UP / DOWN tests.

Execute a few short left and right maneuvers to fill the circuits and thereby purge the system of all air. After each maneuver, check and fill if necessary, the hydraulic tank. Repeat until the level remains stable. Do not allow the Electro-pump to run dry.

Warning All hydraulic systems develop very high pressures. Failure of piping, connections etc that have been improperly installed, will most likely happen on start up. Stay clear of these components. Wear eye protection, and be aware that high-pressure oil can cause major skin damage.

Check the thrust direction :

With the Joystick to the left (port), the vessel should move to port and conversely. If the direction is not correct, inverse to connectors on the hydraulic distributor.

Note the left and right thrust tests must be made under normal conditions of use. In other words that means that the batteries are fully charged that the main engine alternator is running and the batteries are being correctly recharged. (if Electro-pump)

The pressure can be read on the pressure gauge. Important: Close pressure gauge valve after checks.

ADJUSTING THE DCV I SOFT START HYDRAULIC POWER

The DCV valve blocks as supplied by Max power are equipped to start the thruster in a two stage (soft start sequence.)

This is achieved by using bypass system that sends half of the thrusters hydraulic flow directly back to the tank during the first (slow speed) moments after start.

The installers must adjust the speed or power of this first stage during commissioning.

Adjusting (slow speed) BYPASS FLOW.

The bypass valve must remain open during this adjustment process. This is done by

With N.O. bypass valves : disconnecting the wire at terminal 11 in the control box.

With N.C. bypass valves : disconnecting the wire from terminal 11 and connecting it to terminal 32 in the control box.

Doing this will ensure that the bypass valve remains open. The type of bypass valve (N.O. or NF) supplied with your system, is marked on the valve body and in the control box.

Adjusting flow limiter

- 1 Loosen lock nut on bypass flow limiter adjustment screw and open pressure gauge valve (both on DCV)
- 2 Apply thrust in either direction and read the pressure gauge during thrust if the reading is under 100 bar turn the adjustment screw clockwise until the pressure rises to 100 bar .If the reading is to high do the opposite operation to reduce the pressure. When the correct pressure has been obtained hold the adjustment screw (Allen key) and tighten the locknut.

Reconnect the bypass wire to terminal 11. This will cause the bypass valve to automatically close a moment after the pump begins to deliver power and thereby directing full flow to the thruster.

The pressure readings at full speed should correspond with the following.

Model	R300/15	220 to 260 bars	@ 28 to 32 Lpm
Model	R300/21	230 to 270 bars	@ 45 to 55 Lpm

Variations are possible depending upon the installation. After these adjustments are made, do not forget to close the pressure gauge (no. 10) isolating valve.

OPERATION AND USE

Operating Procedure

Switch on the system power breaker normally found on the ships main breaker panel

On the control panel

- Turn to the right, the red button switch. The red lamp will light, indicating that power is available, and the turbine is in the raised position.
- Pull the joystick towards yourself (aft or down), the red light will extinguish, the alarm buzzer will sound until the green light illuminates. The unit is ready for use when the green light is lit and the buzzer is silent.
- Move the joystick to the left (port), the vessel will move to the port and conversely.

Use the thruster as required. If the alarm buzzer sounds and the green light is still on during operation, stop the thruster immediately. This alarm indicates that a problem has occurred on one of the auxiliary alarms.

R300 EHP only – If the alarm sounds during operation, quickly finish the maneuver. This alarm indicates that the Electro-pump has reached a high temperature. Wait for approximately 30 minutes before re-using the thruster. (Depending on ambient temperature)

When finished reverse the above operation move the joystick away from yourself (forward or up), the green light will extinguish, the alarm sounds until the red light illuminates indicating that the RETRACT is fully retracted. It is now safe to advance at normal cruising speeds.

CAUTION Never leave the RETRACT in lowered position when not in use. The RETRACT must be in up position (retracted) when sailing.

The RETRACT is designed to be used in harbor when maneuvering at low speed (below 3 knots). Above this speed, the unit may start to come up **but will not lock**. You must still retract the turbine by using the joystick!

General Operating Data

R300 EHP - Estimated maximum overall and intermittent operating times (before heat accumulation produces too high a temperature in the Electro-pump)

Intermittently	3 min (class S2)
Continuous operation	2 min (class S2)

The Electro-pump motor should have approximately a 30 minute rest period after maximum use. These figures are conservative and for ambient temperatures of 20 degrees C. they are also highly dependent upon the fresh air ventilation of the Electro-pump motor. In fact the motor is self-ventilating when in operation and when

stopped does not ventilate itself. All motors are equipped with a 120/130 c temperature sensor that will sound the alarm buzzer if that temperature is reached. For longer service, extra air cooling of the Electro-pump unit can be installed, such as a forced air ventilating fan. Also increased battery capacity may need to be provided. The thruster should always be used with charged batteries and with the main engine's alternator running and charging the batteries.

R300 hydraulic motor driven Series

A conservative estimate of the maximum overall and intermittent operating times for all the R300 models (before heat accumulation produces too high a temperature in the hydraulic circuit) depends on these factors.

Intermittently	15 min at 20°C
Continuous operation	5 min at 20°C

For longer service periods, Max Power recommends an optional heat exchanger and water pump installation to provide extra oil cooling.

TROUBLESHOOTING GUIDE

PROBLEM

Thrust stops almost immediately after it has been applied. The alarm buzzer comes on and the green light turns off.

PROBABLE CAUSE 1 The Raise/lower Electro-pump unit is not working correctly.
REMEDY : Check that the Raise/lower unit has 24 VDC power to the motor. Check that the pump operates in down position before the thruster starts.

PROBABLE CAUSE 2 The green (B) position switches out of adjustment.
REMEDY Readjust the green (B) position switch by loosening its securing nut and readjusting it closer to the actuator.

PROBLEM : The thruster seems to be developing less thrust.

PROBABLE CAUSE

R300 ELECTRIC SERIES Battery voltage is low
R 300 motor pump SERIES Electro-clutch is slipping

REMEDY

Charge batteries.
Clean clutch .

SECONDARY CAUSE Low oil pressure. Contamination of hydraulic oil filter. Etc...
REMEDY Check pressure. Check and clean the filter (top of the reservoir). Check condition of oil.

THIRD CAUSE Propeller problem (plastic bag, rope, etc...)

PROBLEM The turbine retracts, but the alarm does not stop or the red light does not illuminate.

PROBABLE CAUSE An object such as a line, plastic bag, or other flotsam is caught between the closing plate and the hull.

REMEDY Raise and lower the unit a few times to see if the object clears. If it does not, try to remove the object manually.

WARNING Make sure that the system has been turned off at the main breaker, before putting your hand into the opening of the hull.

PROBLEM The RETRACT will not Retract. (No reaction at all)

PROBABLE CAUSE No power (24 v dc) to the Raise/lower unit.

REMEDY

Check the 20 amp or 15 amp fuse breaker in the control box,

Check that wire number 5 has power,

Check that power is available to the unit, by checking the voltage on wires n° 21 & 22.

Check oil in the reservoir of R/L unit

Check joystick operation.

The RETRACT 300 is equipped with a manual override device (bar) which can be used for raising the RETRACT turbine from the DOWN to the UP position. (Note : it can also be used to lower the turbine. Lowering the turbine this way has no practical use while at sea, but can be useful while on the dry).

The manual override device is used in the event of failure of the Raise/lower unit or its power supply, so that the RETRACT turbine may be raised manually. This will enable the operator to continue his voyage in complete security, or raise the RETRACT turbine while in port thereby maintaining the turbine unit in its light-tight box and thus preventing marine growth.

PROBLEM The transmission lube oil tank level decreases.

PROBABLE CAUSE The propeller shaft oil seals are worn.

REMEDY Change the seals at next haul out. In the meantime, fill the transmission with 80 or 90 gear oil, and check the level often.

WARRANTY REQUIREMENT

IMPORTANT : All Test readings must be filled out on the form provided and sent to Max Power by fax no later than one week after the water tests have been completed so that the Max Power standard warranty is correctly validated. This form is attached at the end of this manual.

MAINTENANCE OF THE RETRACT

Regular checks

1. Lower and raise several times every month
2. Transmission lubricating oil reservoir level.
3. Hydraulic power oil reservoir level.
4. Hydraulic hoses for chaffing and leaks.
5. Condition of the anodes

Control panels, like all external equipment, should be protected from the sun and weather. Clean with a soft cloth and mild detergent solution.

Yearly checks boat ashore

1. Clean the turbine, gearbox and the propellers with a sponge and detergent soap. It is also advisable to remove the top cover plate and clean the interior of the caisson and rinse well the articulated joints.
2. Clean the surface corrosion and repaint the hydraulic motor.

IMPORTANT: If the vessel will remain out of the water for some time, for example: dry storage for the winter, the top cover plate must be removed and the RETRACT mechanism must be thoroughly rinsed with fresh water, especially the articulated joints. Do not operate below 0° C.

3. Inspect and replace all anodes of the unit. If the anodes are not consumed, check for signs of galvanic corrosion or electrolysis to the body of the RETRACT.
4. Change transmission oil, if you find water in the drive leg oil check seals.
5. Remove the propellers and check oil seals replace if necessary.
6. Inspect and repair the hull closing plate gasket for deterioration or missing pieces. Check and tighten if necessary, the plate fixation bolts.
7. Apply antifouling paint to the closing plate on the outside, on the edges and if desired to the plates inner surface. If you find growth on the unit, this is because your closing plate gasket allows light to enter the enclosure.

CAUTION: Do not use antifouling or other copper based paints on the RETRACT turbine.

8. The transmission oil must be changed each year. This can be done by extracting the sump plug screw. Never let the oil level in the lube tank descend below the level of the ships waterline.

9. Check the entire hydraulic system hoses and connections for possible chaffing and leaks.
10. Every two years, drain the entire hydraulic oil system. Properly clean or replace filters in order to protect the hydraulic circuit in general.

5 YEARS

Complete removal of unit and return to authorized dealer or factory

1. Replacement of all submerged flexible hoses.
2. Replace all oil seals and check for bearing wear.
3. Service of hydraulic motor
4. Striping and re anti corrosion treatment plus painting of submerged unit .
5. Service of complete hydraulic oil system included pump, distributor, etc...

IMPORTANT

**PROJECT MANAGER'S
TEST RESULTS FORM**

**To be filled out and
faxed to MAX POWER**

II. TEST RESULT FORM (part 1)

This form must be filled out and faxed to MAX POWER within a week after launching so that the MAX POWER standard warranty is validated.

<p>MAX POWER</p> <p>10 allée François Coli Via Philips 5, 20900 Monza (MI) Italy</p> <p>Tel : (39) 039 200 1973-936 Fax : (39) 039 2004299</p>

<p>From :</p> <p>.....</p> <p>.....</p> <p>.....</p> <p>.....</p> <p>.....</p> <p>.....</p>

Date :

REFERENCE : S __ .R3 _ . _ _ _ _

- Shipyard that installed the RETRACT :
.....
- Name of the Project Manager :
.....
- Name of the Vessel :
.....
- Type & Make of the Vessel :
.....
- Date of launching :
.....

Please answer by YES or NO the following questions concerning the installation :

		YES	NO
1	Is the RETRACT mounted parallel with the bottom of the hull ?		
2	Is there enough room for general maintenance of the RETRACT and its auxiliary equipment ?		
3	Does the closing plate rest upon a flexible gasket ?		
4	Is the adjustment of the closing plate done in such a way that no light is allowed to enter ?		
5	Are the anodes correctly fitted to the closing plate supports ?		
6	Is the lube oil reservoir mounted at a minimum of 1000 mm (39") above the waterline ?		
7	The RETRACT is not glued to the mounting base ?		
8	Does the electro pump have adequate cooling and is the oil reservoir mounted above ?		
9	Is the soft start adjusted /100 bars ?		
10	Are all electrical wires numbered at each end and with their terminals tinned ?		
11	Is the electrical supply to the remote control box stabilized and independent ?		

TEST RESULT FORM (part 2)

When all the tests have been completed as per the manual, please record the following measurements where applicable.

With the engine(s) running, thruster in the down position, but **not running** :

- 1. Record the charging amps of the alternator(s) * : Amps
- 2. Record the voltage at the remote control box : Volts
- 3. Record the voltage at the battery terminals* : Volts

With the engine(s) running and the **thruster running** (either direction) :

- 1. Record the charging amps of the alternator(s) * : Amps
- 2. Record the voltage at the remote control box : Volts
- 3. Record the voltage at the power battery terminals* : Volts
- 4. Record the voltage at the EHP motor* : Volts
- 5. Record the amperage at the EHP motor* : Amps
- 6. Record the hydraulic pressure : slow speed Bars
- 7. Record the hydraulic pressure: full speed Bars

* : only when using the EHP unit as drive

DATE OF TESTS : LOCATION :

PERSON RESPONSIBLE :

SIGNATURE :

PLC Control functions

DOWN SEQUENCE

- 1 Thruster detected UP and **locked**
- 2 Signal given to go down The signal must continue continuously until all stop
- 3 Up down pump motor energized
- 3 Up Down ,Down Valve opened
- 4 No position detected
- 5 Alarm sounds continuously
- 6 Thruster detected as being down
- 7 All stop (motor &valve) up down valve returns to H position (all open no pressure in ram!)

- 1 Thruster detected UP and **locked**
- 2 Signal given to go up
- 3 No reaction

- 1 No position detected
- 2 Alarm sounds continuously
- 3 Thruster can go up and down if signal is given

This function must stay continuously active even when joy-sic or control panel is switched off

UP SEQUENCE

- 1 Thruster detected as being down
- 2 Signal given go up .The signal must continue continuously until all stop
- 3 Up down motor energized
- 4 Up down up valve opened
- 5 No position detected
- 5 Alarm sounds continuously
- 6 Thruster detected as being up
- 7 All stop (motor &valve) up down valve returns to H position (all open no pressure in ram!)

- 1 Thruster detected down
- 2 Signal given to go down
- 3 No reaction

- 1 No position detected
- 2 Alarm sounds continuously
- 3 Thruster can go up and down if signal is given

This function must stay continuously active even when joy-sic or control panel is switched off

THRUST SEQUENCE

- 1 Thruster detected as being Down
- 2 Signal given to thrust (port or starboard) The signal must continue continuously until all stop
- 3 Up Down pump Motor energized
- 3 Down valve opened
- 4 Hydraulic power arrives in the direction required port A & B on thruster unit (power must arrive progressively using a soft start system)
- 5 Signal stops
- 6 Hydraulic power stops
- 7 All Stop (motors &valves)

MAX POWER

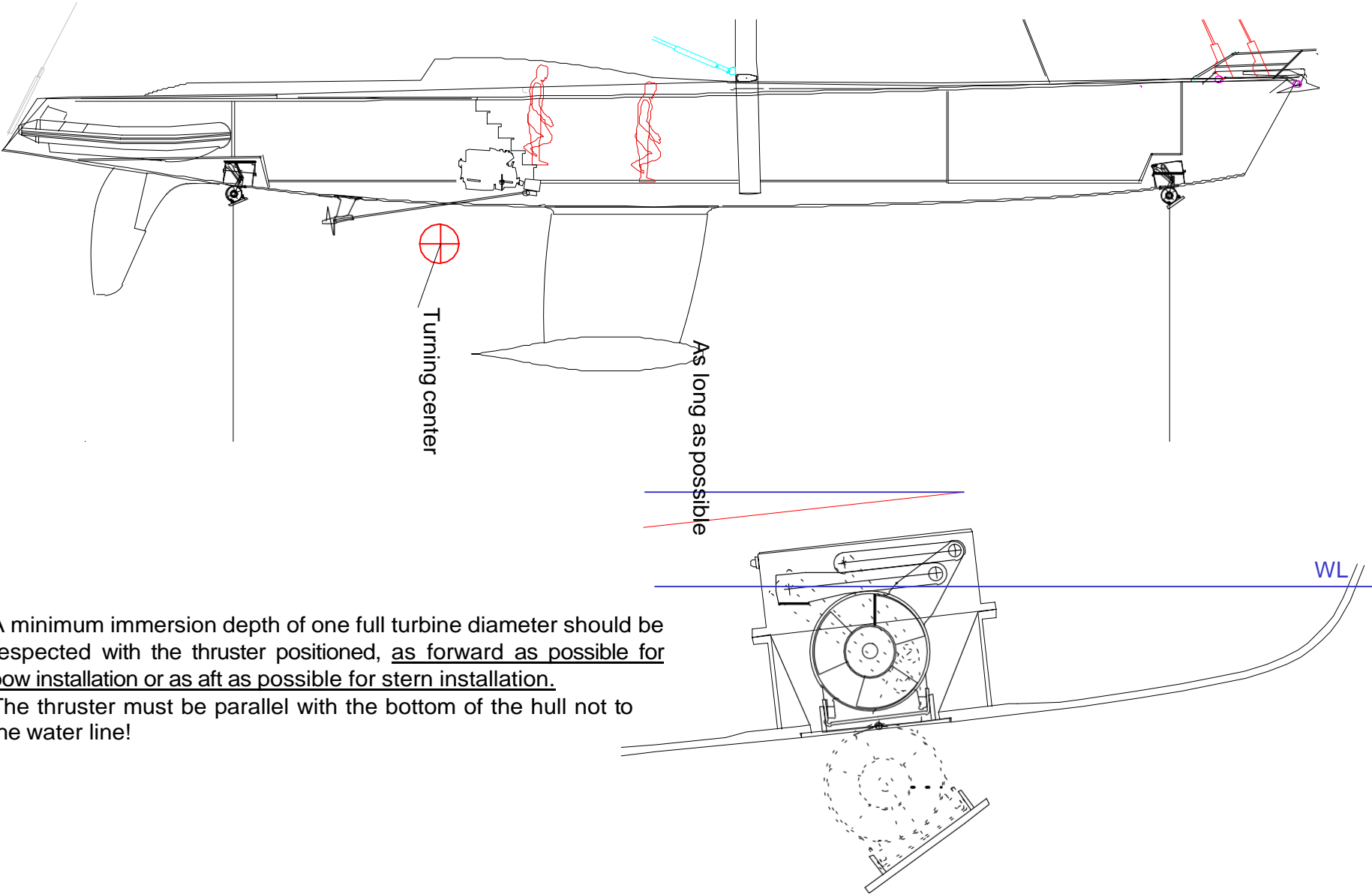

A minimum immersion depth of one full turbine diameter should be respected with the thruster positioned, as forward as possible for bow installation or as aft as possible for stern installation.

The thruster must be parallel with the bottom of the hull not to the water line!

MAX POWER

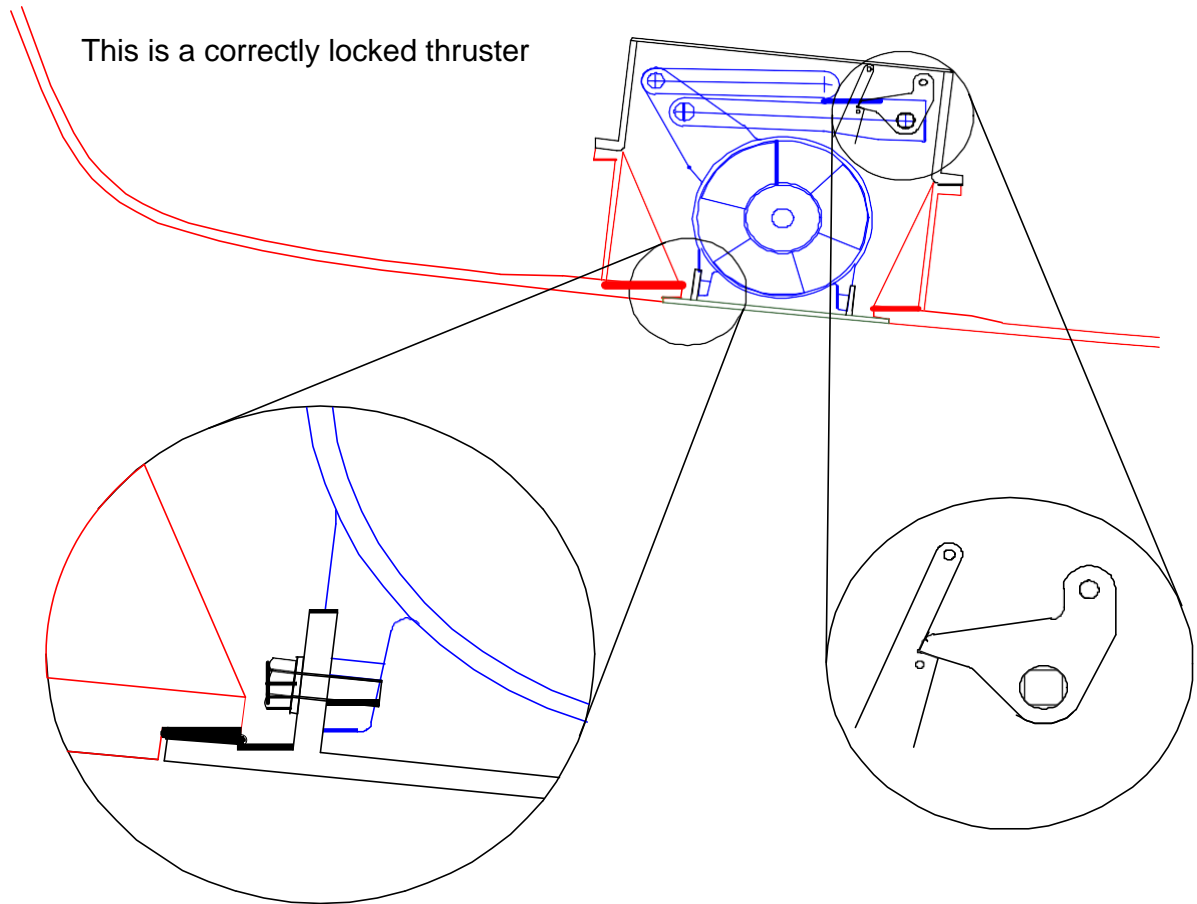

Fig 1

Caution this situation would cause damage to the turbine while at sea .

In this situation there is still up wards movement possible

Fig 2

This gap is essential it should be of at least 5mm

Gap

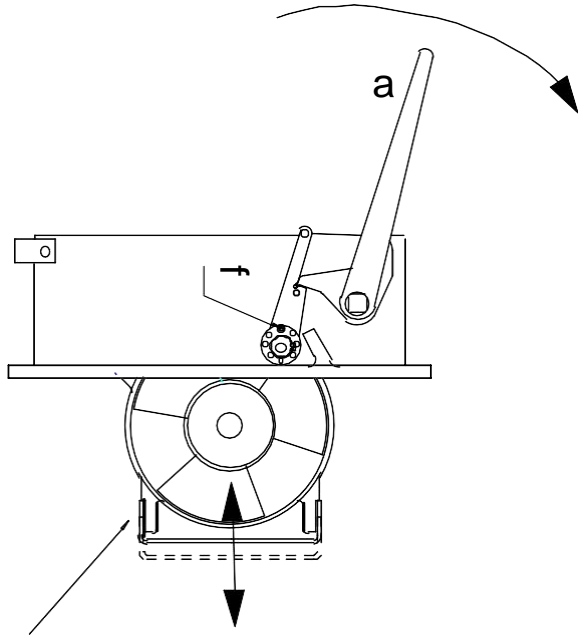

Initial adjustment must be made using the elongated holes in the closing plate mounting

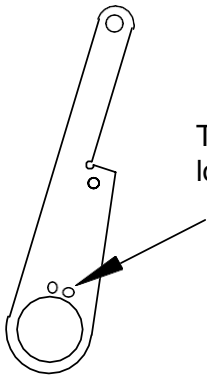

Two holes are available in the locking bolt

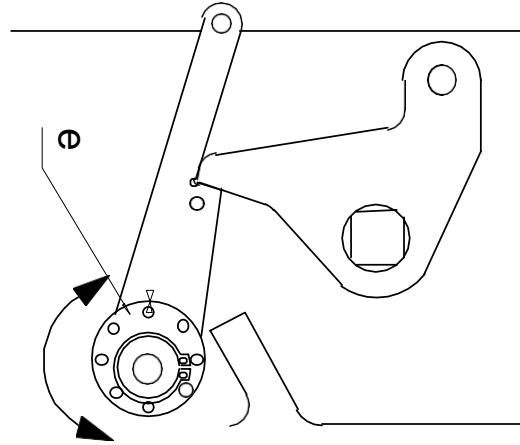

Fine adjustment of the locked position of the turbine is achieved by turning the white plastic cam (e) as on diagram

Hull closing plate adjustment

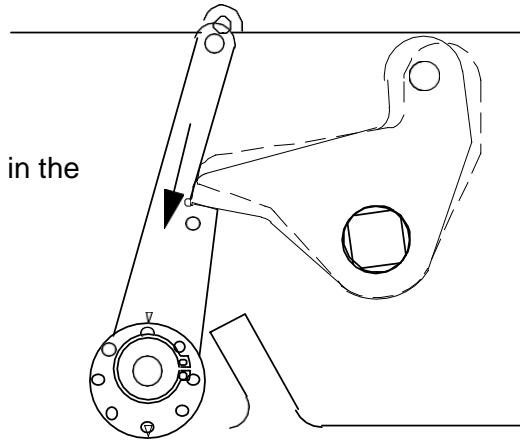

Total fine adjustment allows for 10mm of closing plate movement

MAX POWER

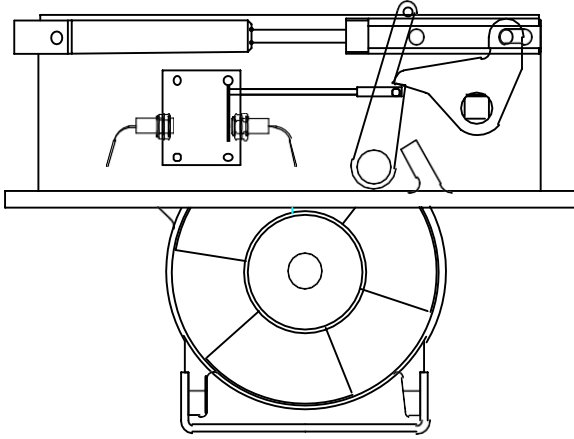

Turbine up and locked

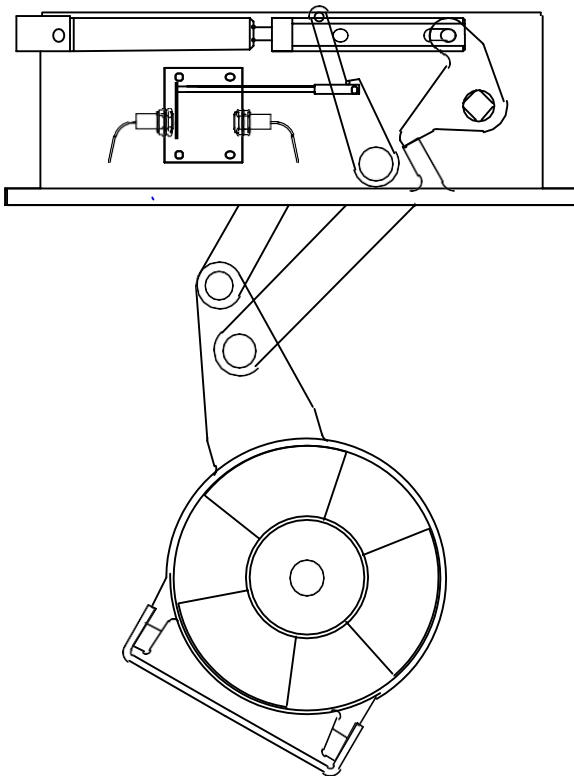

Turbine down and detected
as being down

MAX POWER

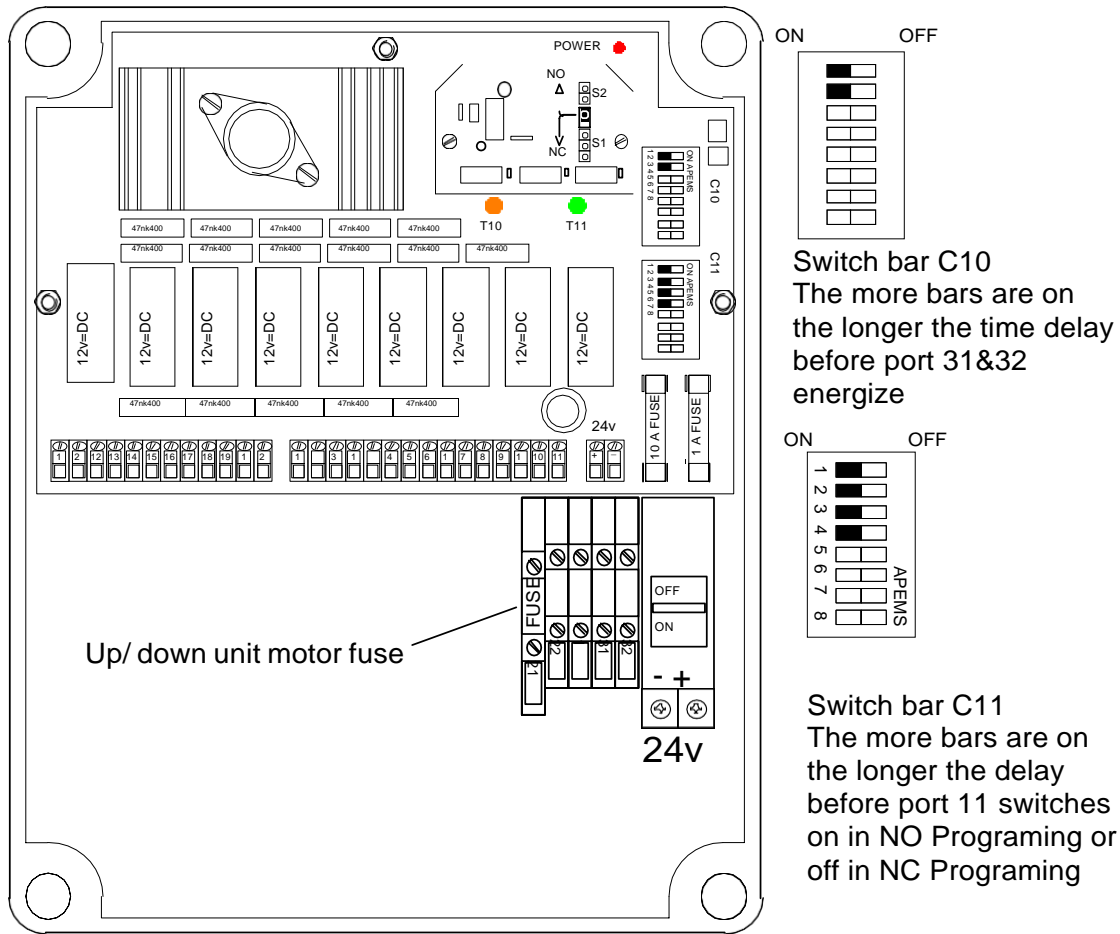

ON APEMS

T10 2 3 4 5 6 7 8
T 10 indicates prime mover status
Ports 31 neg and 32 pos

ON

T11
T 11 Indicates bypass status
port 11 and any 24v neg

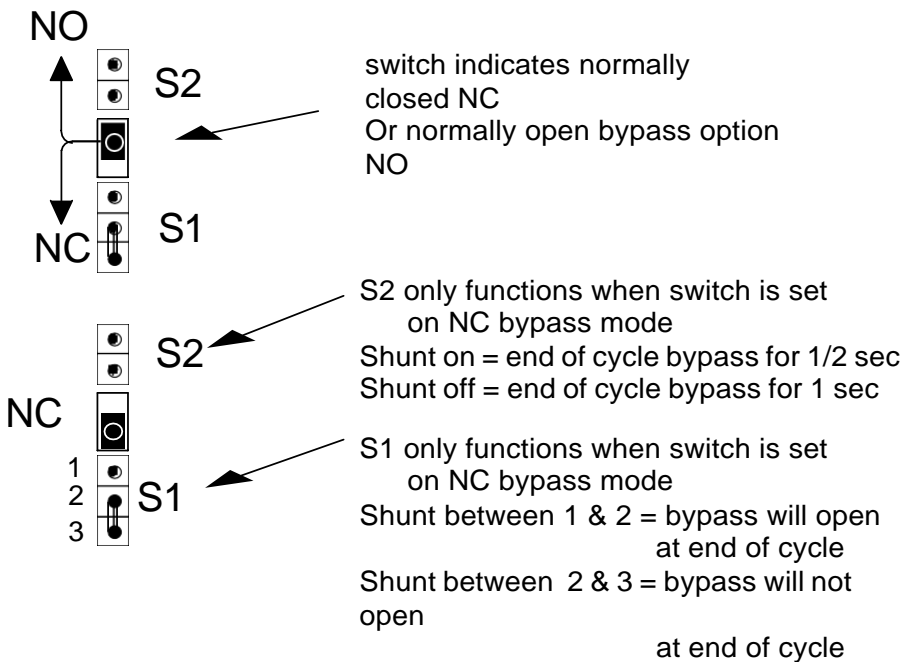

If you have a complete MAX POWER system all card programming is pre set

MAX POWER

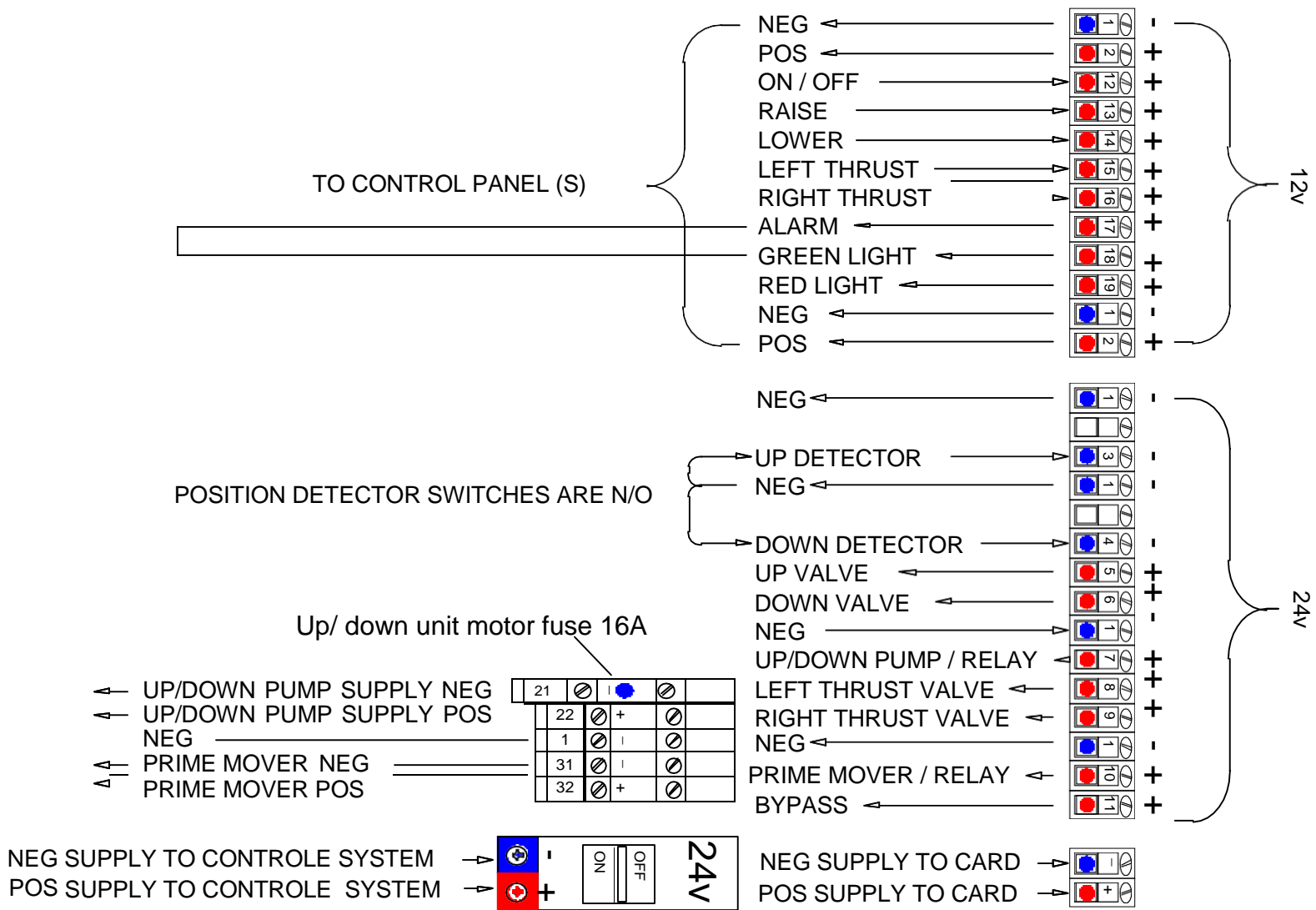

MAX POWER

Foot Switch/Custom Control Panel

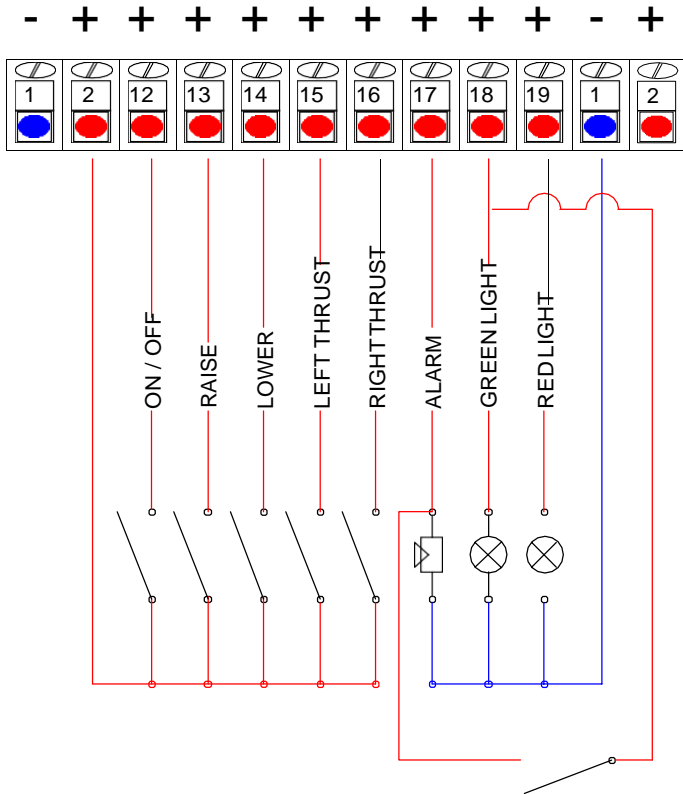

Foot switch /custom control panel

All control switches used should be of N/O momentary push button type with the exception of the on/ off which should be of switching type

Any N/O switches or sensors can be used for complementary alarms at will

Standard R300 Control Panel

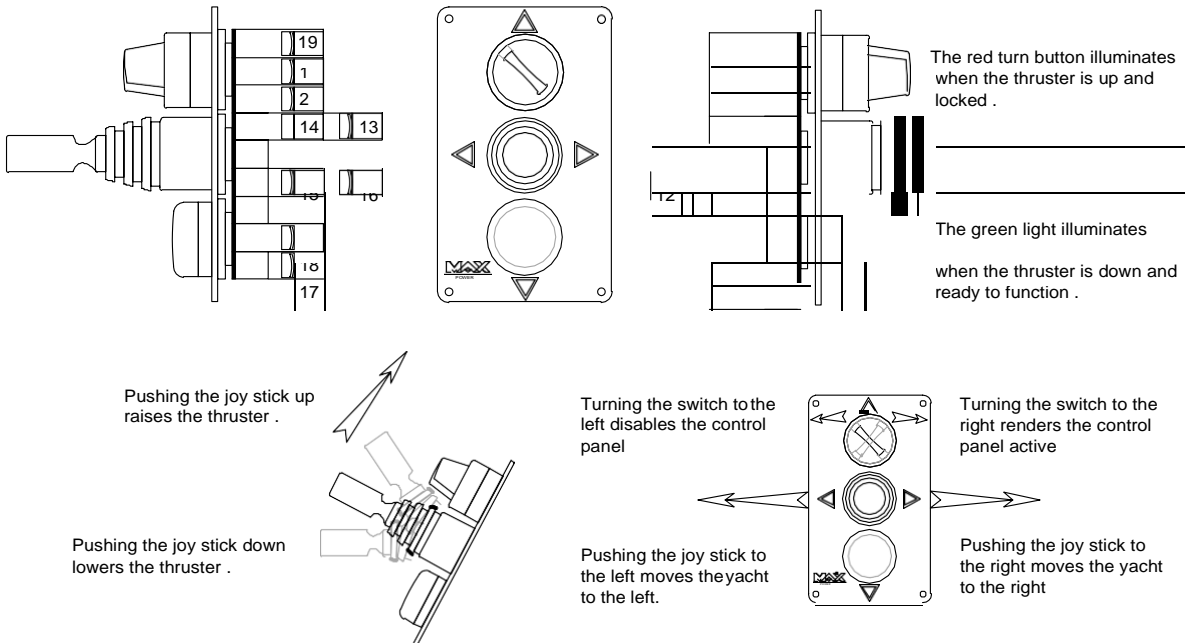

Control system wiring diagram R300 & R450

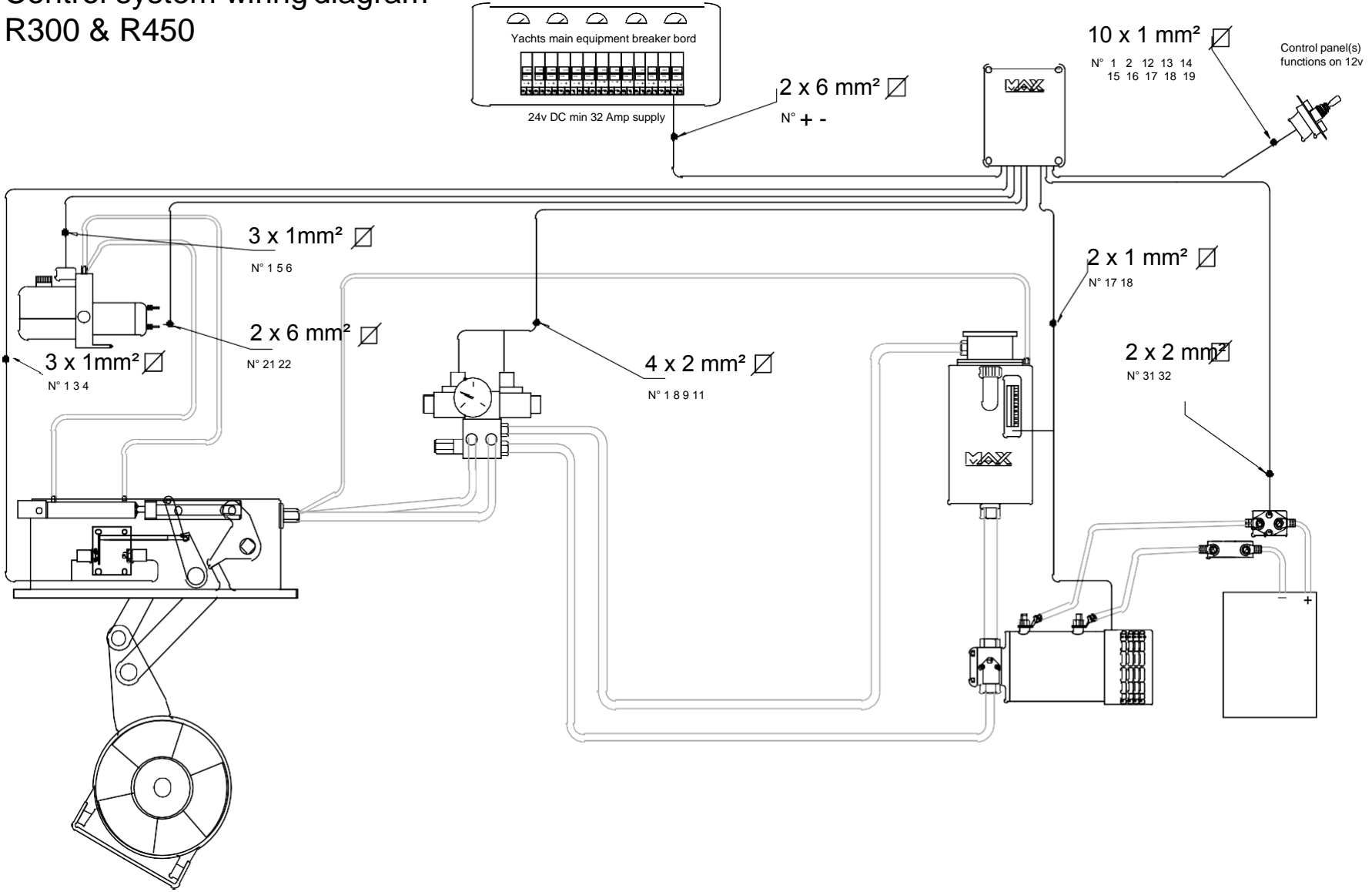

MAX POWER

Control System Wiring Diagram for R300 & R450

MAX POWER

Power System Cabling

Power system cabling
(EHP only)

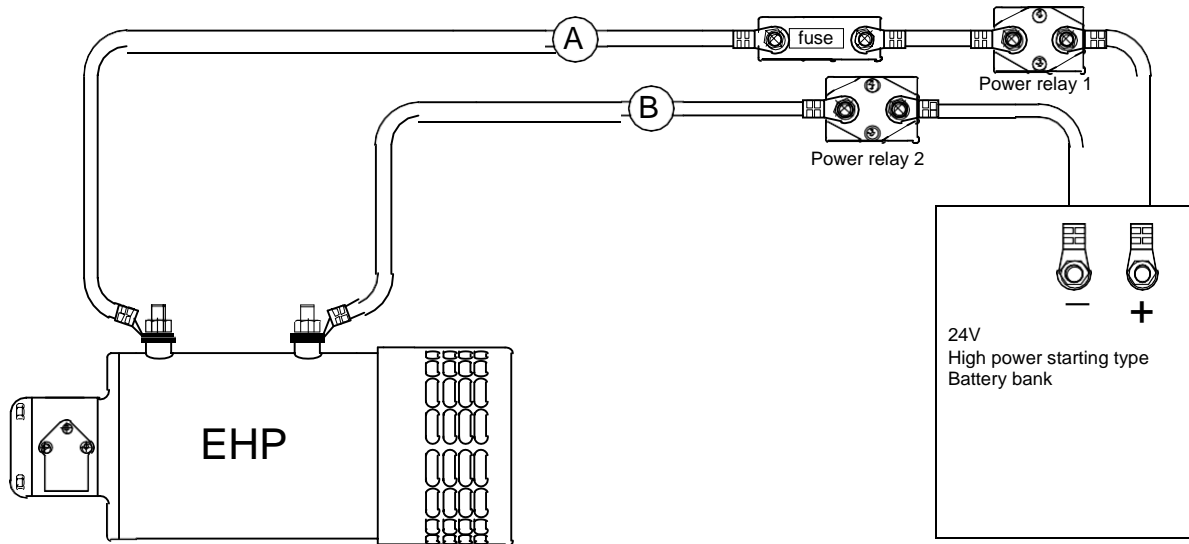

Cable sections

Modle R315/4		Modle R321/4 2 x separate cabling	
Total length in meters	Cable section in mm ²	Total length in meters	Cable section in mm ²
A + B = 1m	95mm ²	A + B = 1m	70mm ²
A + B = 3m	120mm ²	A + B = 3m	95mm ²
A + B = 5m	150mm ²	A + B = 5m	120mm ²
A + B = 10m	190mm ²	A + B = 10m	150mm ²

MAX POWER

R300 Hydraulic Connections

R300

Installation of the hydraulic circuit should be fitted by a hydraulic technician .The hydraulic hoses should be crimp connected , and pressure tested .

HYDRAULIC HOSES : ○

SRP : Suction hose from oil tank to the pump ;Low Pressure (L P) minimum 3/4 " 1" 1 1/2"

PPD : Supply feeder hose from pump to hydraulic directional valve ;
High pressure (H P) 1/2 " or 3/4"

DAR : Supply from hydraulic directional valve to the retract ; HP thermo plastic hose 1/2"

DBR : Supply from hydraulic directional valve to the retract ; HP thermo plastic hose 1/2"

RD : Motor drain from retract directly to oil tank ; LP hose minimum 1/4 " or 5/16"

RT : Return to oil tank ,from the directional valve ; HP hose 1/2" or 3/4"

G : Supply of lub oil to leg gear housing ; LP hose 8mm

LV : Synthetic 100 bar pressure Hoses 3/16" or 1/4"

CONNECTIONS / FITTINGS : ◊ (As supplied on max power equipment)

S1 : Female 3/4" BSP

P1 : Female 1/2" BSP

T1 : Female 3/4" BSP

A1 : Female 3/4" BSP

B1 : Female 3/4" BSP

G1 : Male 8mm

D1 : Male Push on (weak link)

LA/LB : Male 7/16 jic 37°

S2 : Female 3/4" BSP

P2 : Female 3/4" BSP

T2 : Female 3/4" BSP

A2 : Male 3/4" jic 37

B2 : Male 3/4" jic 37

G2 : Male 8mm

D2 : Female 1/4" BSP

VA/VB : Female gas 1/8"

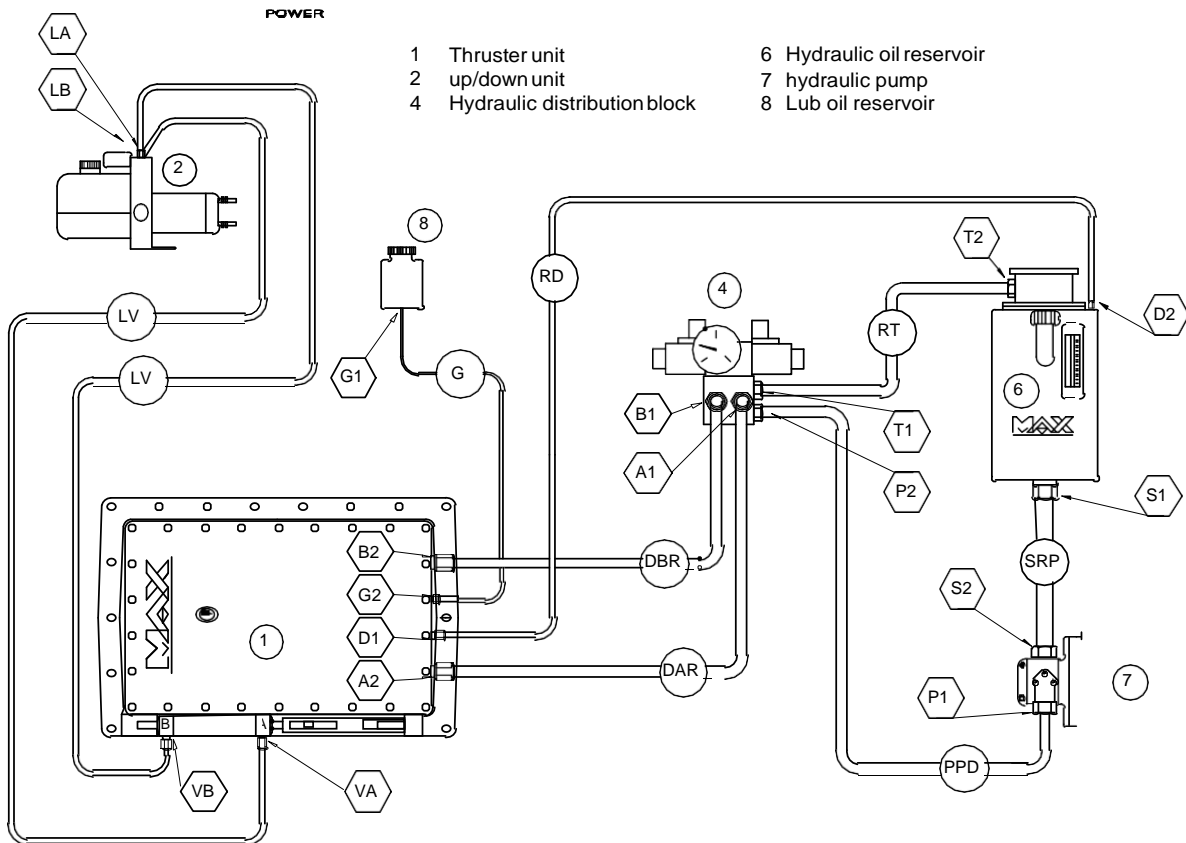

RETRACT R315/R321 Motor Driven

- | | |
|--|--|
| 1 Thruster assembly | 5 Control panel |
| 2 Complete up/down unit | 6 Hydraulic oil reservoir with filtration system |
| 3 Control box | 7 Hydraulic pump |
| 4 Hydraulic distribution/soft startblock | 8 Clutch PTO adapter |

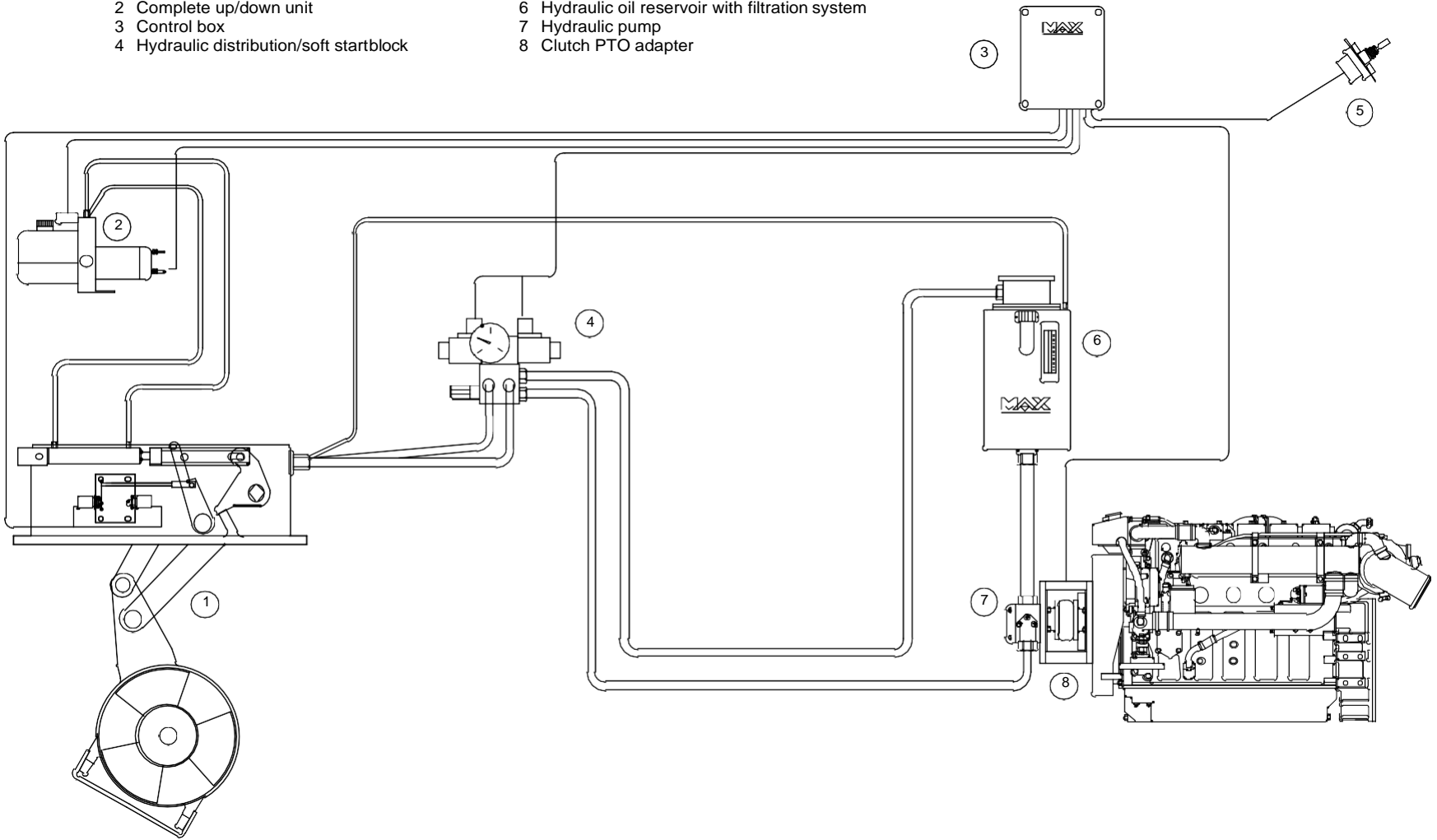

MAX POWER

R315/R321 Motor Driven

RETRACT R315 EHP

- 1 Thruster assembly
- 2 Complete up/down unit
- 3 Control box
- 4 Hydraulic distribution/soft start block
- 5 Control panel
- 6 Hydraulic oil reservoir with filtration system
- 7 Electro hydraulic pump EHP
- 8 Power relay/power fuses

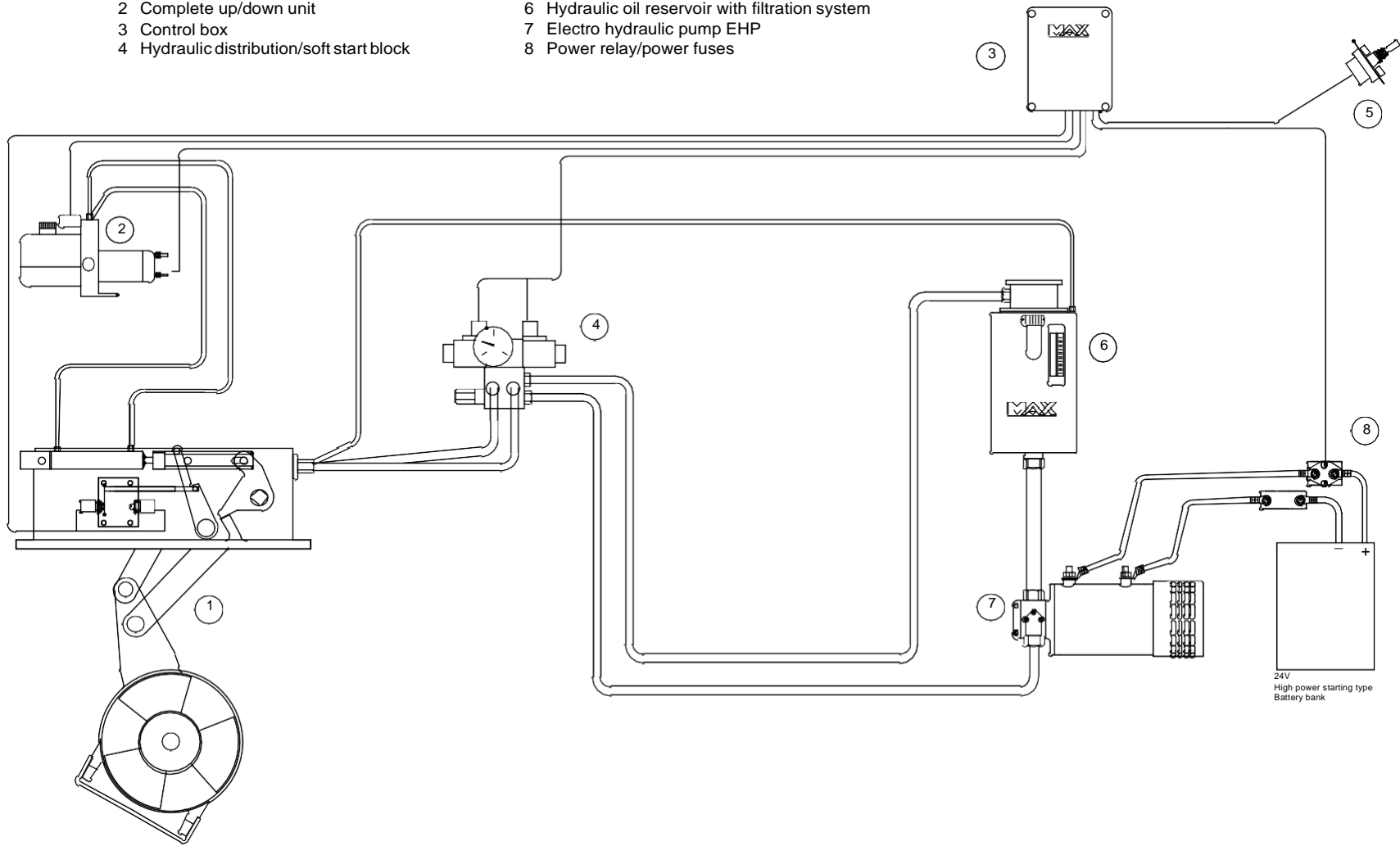

24V
High power starting type
Battery bank

MAX POWER

R315 with Electro Hydraulic Pump

MAX POWER

R300

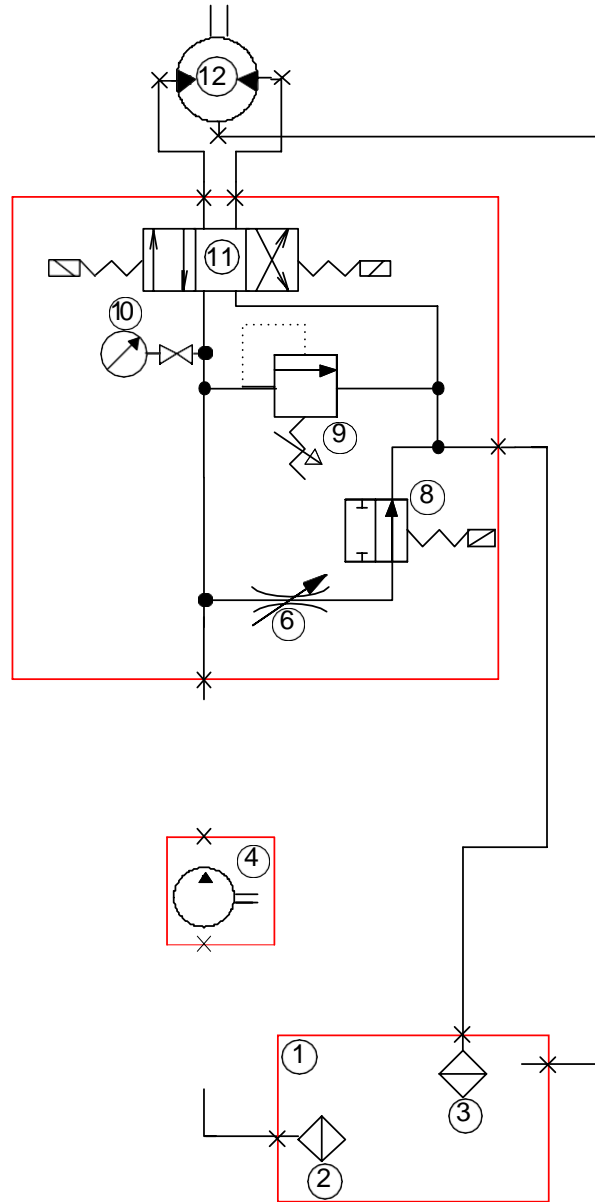

- 1 :Oil tank
- 2 :Intake strainer
- 3 :Return filter
- 4 :Pump
- 6 :Flow restrictor
- 8 :Bypass

- 9 :Relief valve
- 10 :Pressure gauge and valve
- 11 :Directional control valve
- 12 :Retract motor

WARRANTY COVERAGE

Introduction

The purpose of this document is to set out the terms of warranty cover offered in relation to products purchased by the End User from Max Power or its approved network of resellers.

This document will adhere to the following format:

Section 1	Definitions
Section 2	Period of Coverage
Section 3	Warranty Registration
Section 4	Warranty Terms
Section 5	Warranty Exclusions
Section 6	Procedural Guidelines
Section 7	Service Centers

1) Definitions

Authorized Repair Number – The number given by Max Power on reporting a fault with your thruster

Dealer – An authorized Max Power sales centre

End User – The boat supplied with supplied equipment and the owner thereof *Installer* – The authorized centre responsible for the installation of your thruster *Manufacturer* – supplier of the equipment under warranty

Pleasure Craft – Vessels used for owner's personal use that have no commercial use (i.e Charter boats or work boats)

Resellers – Max Power approved distributors and dealers

Serial Number – Number in upper right hand corner of Warranty document

Supplier – The manufacturer (Max Power)

Warranty – The terms and conditions that are covered by the manufacturer

2) Period of Coverage

The equipment manufactured by the Supplier is guaranteed to be free from defective workmanship, components and materials under normal usage conditions for a period of two years from the date of purchase by the End User. This warranty is transferable to subsequent owners of this equipment during the period of coverage.

3) Warranty Registration

Register your purchase now to receive free extended warranty coverage. This can be done using one of the following methods (NB. proof of purchase must be included to establish that equipment is still under warranty):

The quickest and easiest method to register your warranty is to send the attached installation check list and warranty registration to the Manufacturer via email or fax:

(Fax: +33 4 92 19 60 61)

Mail in your warranty registration document, please ensure that you make a copy before sending it.

4) Warranty Terms

If the material is used for anything other than for pleasure craft, the guarantee is limited to a six-month period.

Year 1 -All factory testing, diagnosis, repairs and replacements are performed at no charge to the End User. All parts and up to two hours of labor are covered for repairs and replacements conducted in the field.

Year 2 -All factory testing, diagnosis, repairs and replacements are performed at no charge to the End User. This excludes any damage or faults occurring from normal wear and tear on the following items: engine, oil seals, relay contacts (If warranty is registered within the 3 month period following installation)

5) Warranty Exclusions

Damage due to modifications or installation contrary to published specifications

Damage due to electrolysis or galvanic corrosion between the hull and the RETRACT body

Cost of hauling the boat

Damage due to repairs performed by an unauthorized service centre

Damage due to lack of normal maintenance services

Damage due to water

Parts replaced due to normal wear and tear

Repairs performed without knowledge of manufacturer (please contact dealer to receive Repair Authorization Number)

Tampering of equipment by the End User Cost of travel to and from the job site

Cost of economic loss, including injury to any person, damage to property, loss of income or profit, communication, lodging, inconvenience

Consequential damage due to failure, including those arising from collision with other vessels or objects

6) Procedural Guidelines

PLEASE VIEW THE TROUBLE SHOOTING LIST TO ASCERTAIN OR SOLVE ORIGIN OF PROBLEM PRIOR TO CONTACTING THE DEALER/INSTALLER

Contact your dealer/installer to report the problem.

If you do not know who this is contact the nearest Max Power distributor

If you are in foreign waters please contact the nearest Max Power distributor

Ensure you have your serial number and model number to hand (top right hand corner of warranty)

Dealer/Installer will come to site to decipher the cause of the fault

If the cause of fault is due to a manufacturing problem the dealer will contact Max Power to receive Repair Authorization Number.

If the problem is due to an installation error please contact your installer.

IF POSSIBLE: PLEASE TAKE PHOTOGRAPHS OF THE THRUSTER TO SHOW PROBLEM

The warranty as outlined above is only applicable to Max Power manufactured thrusters and optional equipment as used in marine pleasure industry. The supplier holds the exclusive right to test the product and determine whether it is defective

