

MAX
P O W E R
CONTROL TO THE MAX

MANUAL

MAX POWER RETRACT R450

FOR _____

BUILT BY _____

DELIVERED _____

∫ ***A copy of this manual must remain
on board for consultation.***

MAX POWER

CONTENTS

INTRODUCTION

- P3 CONTACTING MAX POWER
- P3 IMPORTANT GENERAL INFORMATION
- P3 CHECK LIST FOR THE PROJECT MANAGER

DETERMINING BEST EQUIPMENT LOCATION

- P4 OF THE RETRACT THRUSTER UNIT
- P5 OF THE AUXILIARY EQUIPMENT

INSTALLATION PROCEDURES

- P5 CONSTRUCTION OF THE MOUNTING BASE
- P6 CONSTRUCTION OF HULL OPENING & CLOSING PLATE
- P7 FINAL FITTING OF THE RETRACT UNIT TO THE MOUNTING BASE
- P7 FINAL ADJUSTING OF THE CLOSING PLATE
- P8 RAISE/LOWER POWER PACK INSTALLATION
- P8 TRANSMISSION LUBE OIL TANK INSTALLATION
- P9 HYDRAULIC POWER SYSTEM INSTALLATION
- P10 ELECTRICAL SYSTEM INSTALLATION
- P10 CONTROL SYSTEM

CHECKS, TESTS & ADJUSTMENTS

- P11 BEFORE LAUNCHING
- P11 AFTER LAUNCHING

OPERATION AND USE

- P12 OPERATING PROCEDURE
- P12 GENERAL OPERATING INFORMATION

TROUBLESHOOTING GUIDE

P 13

MAINTENANCE OF THE RETRACT

P 14

PROJECT MANAGERS CHECK LIST

P 16

TEST RESULTS FORM

P 17

WARRANTY COVERAGE

P18

MAX POWER

INTRODUCTION

AFTER SALES SERVICE

ADDRESS:

MAX POWER
Via Philips 5, 20900 Monza, Italy

TEL : + 39 039 200 1973-936
FAX : + 39 039 2004299

RETRACT SERIAL N° S __ . R4 __ . __ . __ . __

IMPORTANT GENERAL INFORMATION

With a constant concern of improving our products, we reserve the right to make changes to this manual without prior notification.

All statistics and explanations within this manual were believed to be correct at the time of printing.

Each RETRACT installation requires a preliminary study of performance and feasibility.

This study covers 3 distinct sub systems:

1. The RETRACT thruster unit, (positioning ,space available ,structural compatibility etc)
2. Hydraulic equipment, (positioning equipment ,power available , flows pressures pipe sizes etc)
3. Electrical equipment, (positioning ,power supply , protection / isolation ,etc)

CHECK LIST FOR THE PROJECT MANAGER

It is very important to carefully read the entire manual before starting the installation.

At the end of the manual, you will find a MAJOR POINT CHECKLIST when you are inspecting the work of your installers. All the points listed must be strictly respected for the proper and safe operation of the RETRACT system.

MAX POWER

The RETRACT should be installed by a professional specializing in this type of installation.

Architects, construction shipyards and surveyors should be contacted before installation.

All official bodies or classification experts should be contacted before the installation. All mechanical installation must apply with the conditions as laid down in the country of the boats registration.

All electrical installation must apply with the conditions as laid down in the country of the boats registration origin.

All hydraulic installation must apply with the conditions as laid down in the country of the boats registration origin.

WARRANTY REQUIREMENT

IMPORTANT: All Test readings must be filled out on the form provided and sent to Max Power by fax no later than one week after the water tests have been completed so that the Max Power standard warranty is correctly validated. This form is attached at the end of this manual.

DETERMINING BEST EQUIPMENT LOCATION

POSITIONING OF THE RETRACT UNIT

IMPORTANT: Correct positioning is essential for correct operation.

(See drawing 1)

The turbines centre requires to be 675 mm (26 ") below the water-line when fully extended.

In other words the turbine should be at least one full diameter below the water-line.

The following considerations must be taken into account when determining the position of the RETRACT.

- The space available given the vessel's fixtures, space and shape, and the installation at the farthest point forward (or aft) while respecting the minimum immersion of the turbine.
- The structural compatibility of the mounting base.
- The access needed for installation, and removal of unit.
- Sufficient access for all maintenance procedures must be allowed for.
- That the turbine when down is clear of all obstacles that might disturb water flow.

IMPORTANT: Always check and make sure that there is enough room to allow for complete removal of the RETRACT unit, and room for the connection of the hydraulic piping.

NOTE: Always make sure that there is enough room for the manual override system.

MAX POWER

LOCATION OF THE AUXILIARY EQUIPMENT

The transmission lube oil tank and the hydraulic directional valve should be located near the RETRACT unit, but in an accessible and dry place.

The hydraulic oil reservoir must be located above the water line, above and as near to the pump as possible there must be now sharp elbows between the pump and the oil tank.

The control panel (s) joystick (s), or foot switches are to be installed as required at helm stations. The remote control box is to be installed in a convenient dry and well-ventilated position.

INSTALLATION OF THE RETRACT UNIT

CONSTRUCTION OF THE MOUNTING BASE

MAX POWER can supply as an option, a G.R.P. laminated mounting base, aluminium alloy machined mounting-flange. These options allow you to save considerable installation time, and assure precise installation.

The general method and materials used must be adapted to the particular hull material (laminated wood, GRP, sandwich, aluminum, or steel). Naval Architects, Classification Societies or engineering firms should be consulted.

GUIDE BLOCKS

The thruster's mechanical stresses are spread over the hull by the mounting base and the guide blocks. Installation, which should be executed by welding or bonding to the hulls plating, normally reinforces the hull, the mounting base should be attached to frames and stringers as well. The guide blocks should be replaceable should they be found worn at a later date.

After the mounting base has been made, the RETRACT should be temporarily secured on the flange to check its height its, centering, the accessibility of fittings and the ease of operation of manual up down override system.

Another important reason for this is to determine the exact location of the two plastic guide blocks.

These blocks are to be fabricated by the installer from a suitable plastic (PEHD type etc) incompressible with 0 % moisture absorption.

The guide blocks distribute the thrust forces to the hull. They should be fixed to the interior of the mounting base so that they will be directly in contact with the folding arm pivots when the turbine is fully extended (See building plan).

GRP HULLS: The mounting base may be molded into the hull during construction or prefabricated, and then laminated onto the hull later.

MAX POWER

METAL HULLS: The mounting base may be constructed with the hull or prefabricated, and then welded onto the hull later.

NOTE: In both hull cases, the top surface of the mounting base (the flange) must be given **particular attention** and machined perfectly flat in order to accept the « O » ring seal of the RETRACT base flange and ensure perfect water tightness.

The bolts fixing the RETRACT onto the mounting flange must be inserted from top to bottom.

Provide sufficient access underneath the flange to allow for tightening the nuts. If the access is not possible, provide a special mounting flange with metric 12 mm studs or tapped holes.

CONSTRUCTION OF HULL OPENING & CLOSING PLATE

The required hull opening dimensions are: L = 516 mm x W = 300mm.

The longitudinal centre line of the opening coincides with that of the mounting flange. But the transversal centre line of the opening is offset by 30 mm to the rear with respect to the transversal centre line of the mounting flange.

The opening is closed by a plate that may be made from the cutout hull section, or specially fabricated.

This closing plate should bear against a gasket fixed to a **20 mm wide rebate** when in the raised position.

While the hull opening closing plate is being fabricated, the RETRACT must be temporarily secured on the mounting base flange to facilitate correct closing plate installation.

The closing plate **must be fixed** to a fabricated aluminum adjustable mounting, which should have 6 elongated holes for final adjustment).

A gasket needs to be installed in the hulls rebate. This gasket can be made either out of **sealed cell** neoprene rubber or molded in «SIKAFLEX » (or a similar product) to form a flexible seal. Precaution must be taken to ensure that the flexible gasket does not glue the closing plate to the hull while drying. The plate must rest evenly, on the gasket with a reasonable pressure.

The closing plate should be tested for adjustment at this point, using the fixation bolts to hold the plate in place, raise and lower the unit a few times.

IMPORTANT: To prevent marine growth inside the casing, it is essential that once the unit is raised, no light is allowed to enter the turbine enclosure. Therefore the closing plate gasket is essential and requires careful and permanent fixation.

NOTE: Never use antifouling or other paints on the RETRACT unit.

MAX POWER

FINAL FITTING OF THE RETRACT UNIT TO THE MOUNTING BASE

CAUTION: To ensure absolute cleanliness, hydraulic lines and ports must remain plugged until final connection.

Final installation on the mounting base must be made after thoroughly cleaning and then liberally coating both joint surfaces (case and base) with good quality marine grease. This is so that the « O » ring seal is compressed flat, evenly, smoothly and squarely when the bolts are tightened.

CAUTION: Under no circumstances should the RETRACT be glued or bedded down with a marine type mastic/glue such as sikaflex or other similar product.

The flange bolt should be tightened sequentially and in successive passes until the two surfaces touch. If desired, a torque wrench can be used and the bolts can be tightened to a torque of 5,0 kg/M. The flange bolts should be metric size 12 mm of stainless steel, and should have a large stainless steel washer placed above a nylon washer. The nylon washers avoid stainless steel contact with the aluminum case. The nuts should be NYLOCK self-locking type.

The 4 lifting lugs provided by MAX POWER, should be put in a small plastic bag, along with the hydraulic pipe plugs, for storage and future use by the ships crew.

FINAL ADJUSTING OF THE CLOSING PLATE (See drawings N°4 & N°3)

Once the thruster is permanently bolted onto the mounting base, reinstall the plate and check it's adjustment.

The turbine is naturally **closed** at rest because of the gas spring used in the lifting mechanism .It is the force of this spring that **most of the time** holds the plate closed

Adjust the closing plate so that it fits evenly and squarely in its hull recess.

When testing the cover plate fit, use the manual lower mechanism.

Two rubber blocks have been placed on the top of the turbine to help adjust the closing plate in the correct position.

Tighten its fixation bolts (A) then remove the rubber blocks. (Drawing n°3 fig 2)

Be sure that it is the gas spring holding it in place, and that the thruster **is not fully folded with the plate shut** (see drawing n°3 Fig 1)

The closing plate could however **open at sea** because of aqua dynamic forces or because of down ward momentum.

The thruster is therefore fitted with a mechanical locking device.

(See drawing N°2)

Although the RETRACT R450 is delivered completely tested and folded in the folded UP position, the locking slide bar cannot be definitively adjusted at the factory.

Adjustment has been set at the factory in the medium position

MAX POWER

It may be necessary to readjust the slide bar height so that the Bar engages automatically or so that the bar is not loose when the thruster closes. This is done as follows

Loosen the two bolts holding the locking slide guide (F on drawing N°4) and adjust its height by using 19 mm bolt (G).

Correct adjustment has been obtained when Bar engages **automatically with a sharp snap**, and you **cannot pass** a 0.1mm feeler gauge between the locking cam and the locking bar. This adjustment must be achieved with the Up down unit set no higher than 40 bars.

When correct adjustment has been obtained re-tighten the guide's bolts (F).

RAISE / LOWER POWER PACK INSTALLATION

The raise/lower unit should be near the RETRACT unit. It should be installed in a readily accessible and dry place.

It should be connected to the control box with 2 x 6 mm² cable for the motor power and 3 x 1 mm² for the up down spool valves. The up / down unit motor is protected by a 16ah fuse found in the control box.

The hydraulic ports (LA and LB) on the raise/lower pump unit and the raise/lower ram (VA and VB) must be connected A to A and B to B.

The flexible hoses must be 3/16" or 1/4 " with an operating pressure rating of at least 100 bars.

CAUTION: to prevent the risk of electrical earth leakage's, the hydraulic hoses connected directly to the RETRACT should be non-conductive (non-metal braided hose) high-pressure thermoplastic hose. **Absolute internal cleanliness is essential**. After pipes and hoses have been equipped with their fittings, they must be blown out with compressed air, and then plugged until connected.

The pressure limiter on the unit is pre set and should need no adjustment!

If adjustment is needed always use the minimum pressure needed & do not exceed 75 bar.

Do not forget that the unit runs constantly when the thruster is thrusting. It is therefore when thrusting (in particular to stbd) that the maximum pressure can be read.

TRANSMISSION LUBE OIL TANK INSTALLATION

The transmission lube oil tank is no longer used on retract series units.

HYDRAULIC POWER SYSTEM INSTALLATION

Hydraulic power system general

A RETRACT R450/40 Can take **up to** 110 LPM of hydraulic flow this will causes on a normal installation approximately 210 bar pressure at the thrusters inlet ports.

A RETRACT R450/50 Can take **up to** 170 LPM of hydraulic flow this will causes on a normal installation approximately 170 bar pressure at the thrusters inlet ports.

The hydraulic power system should be designed in consequence.

The hydraulic power system must start the thruster gently (soft start) either by using a ramping valve or by using a 2-stage slow/fast speed bypass system.

MAX POWER

The control box is equipped for both but may need re programming.

Please note that a bow thruster does not have a specific pressure the pressure at a given flow can vary by approximately 10 % depending on installation parameters. All the hydraulic power equipment, such as the piping, reservoir, pump, directional valve, etc. should be installed in compliance with the usual rules of accessibility to enable periodic checks and maintenance.

MAX POWER recommends the use of **ISO GRADE 15 to 32 hydraulic oil** for the power circuit.

PRESSURE PIPING

All hydraulic high pressure power circuit piping must comply with high pressure standards, and have a diameter at least equal to that recommended (see drawing N°5) in order to reduce pressure loss especially when the installation's layout requires long hose lines.

All power circuit piping must have a continuous service pressure rating of at least 280 bars. Fittings must be of good quality, and crimped as per manufacturers instructions.

The pump intake hose line (from the reservoir) must be of a quality that is not subject to pinching or crimping.

This hose should preferably be shorter than 2 meters and have no 90-degree elbows bends.

CAUTION: to prevent the risk of electrical earth leakage's, the hydraulic hoses connected directly to the RETRACT should be non-conductive (non-metal braided hose) high-pressure thermoplastic hose. **Absolute internal cleanliness is essential.** After pipes and hoses have been equipped with their fittings, they must be blown out with compressed air, and then plugged until connected.

RESERVOIR

The reservoir should be mounted as close to the pump as possible and must always be higher than any other component in the system, in order to minimize the risk of cavitation. The reservoir must be mounted at a height that allows the breather to be situated 500 mm, or higher, above the waterline. If this is not possible, then the breather can be removed and installed on the end of an extension pipe or hose.

Mounting the reservoir too low could result in oil draining back, or overflowing the tank. Be sure to allow enough space above the reservoir to service the filter.

If MAX POWER does not supply the reservoir, then provide a return filter of 60 microns and a suction strainer.

The reservoir must be flushed after installation.

MAX POWER

DIRECTIONAL CONTROL VALVE

The directional control valve (DCV) must be placed between the pump and the RETRACT unit, it is recommended to locate the DCV as near to the RETRACT as possible (in an accessible and dry place).

The DCV block used must be equipped with a pressure gauge so as to check operating pressure on commissioning and for maintenance.

The block must be equipped with a pressure relief valve set to 220 bars.

If a central system is used a cross line relief valve can be used.

(See Drawing N°6)

ELECTRICAL SYSTEM INSTALLATION

Although MAX POWER has used the best materials available, the installer should endeavor to install all electrical equipment with the view that it should be in a ventilated and dry environment at all times. Control panels mounted at helm stations must be provided with protection if the station is exposed to the weather.

All wiring must be insulated from ground and its installation executed in compliance with safety and classification standards.

CONTROL SYSTEM

The Retract R450 control system is all centralized in the electronic control box
All numbers indicated on our diagrams must be connected 1 to 1 and 2 to 2 wire sections must be respected to the letter.

The control box command's the up down unit and hydraulic power spool valves in the correct sequence with correct timing. (Sequence chart with diagrams)

There is scope for modifying sequence timing in this box but consult MAX POWER FIRST! (See diagram N° 8)

All Retract equipment is connected to this box (See diagram N° 9)

All wires should be carefully **labeled to reduce the chance of error** and simplify checking and troubleshooting.

All wire ends for terminals should be tinned before inserting into terminal blocks.

The control system of the RETRACT requires 30 amps of stabilized 24 v dc power. The 24 volt input power is automatically transformed to produce 12 volts for the control panel use **control panel only**.

The major power consuming components of the RETRACTS electrical system (the raise/lower unit, the directional valve solenoids, and the electromagnetic clutch) are supplied with 24 volts **from the** control box.

Complimentary alarms may be added at will (over heat, low oil level, etc.) as on Diagram N°10

Switching the thruster **system** on is achieved by a two-pole 32-amp circuit breaker (not supplied by Max Power), which should normally be located on the main electrical panel.

MAX POWER

CHECKS, TESTS & ADJUSTMENTS

BEFORE LAUNCHING

IMPORTANT: Before the launch, verify that the RETRACT unit inspection top plate has been replaced (if it was removed during installation) and that all the lower flange bolts have been tightened. Torque for all these bolts is 5 kg/m.

IMPORTANT: The cathodic protection system on board must provide sufficient protection to the aluminium body of the RETRACT unit against galvanic corrosion or electrolysis. The RETRACT unit must be grounded by connecting a bonding wire to the main cathodic protection system.

Filling the hydraulic circuit.

MAX POWER recommends the use of **ISO GRADE 15 to 32 hydraulic oils** for the power circuit. This mineral oil has already been used by Max Power during the run in tests and consequently the RETRACT motor and piping are already filled with this kind of oil.

CAUTION : Biodegradable and mineral (commonly used) oil are non compatible and should not be mixed or used together. Mixing them will deteriorate certain hydraulic elements. If you intend to use a biodegradable oil, thoroughly flush the existing mineral oil from the RETRACT unit first with the appropriate oil.

Before carrying out the below test we recommend to disconnect the wire at terminal N° 32 in the control box:

- Check all fittings for tightness and leaks.
- The transmission is already filled with oil at the time of delivery.
- Max Power uses HYPIOD HD 80W/90 oil (quantity 1,6lt) in the transmission; therefore, fill the transmission lube oil header tank with similar grade oil. The function of this lubricant tank is to ensure a constant pressure, as well as a visual control of the oil-level. The tank should be filled to the $\frac{3}{4}$ level. Purge air in tube before fitting the pipe to the RETRACT.
Performing the UP / DOWN tests (standard joystick control panel).
- Check UP / DOWN operation.
- This unit has a second function, in that it blocks the turbine in the down position when thrust is applied.
Move joystick to port or starboard and check that the up/down hydraulic pump is pushing the turbine down.

Remove the rubber spacers between the turbine and the lifting arm

AFTER LAUNCHING

- Check for water leaks.
- Switch on the system power at the breaker and repeat the UP / DOWN tests.
- Execute a few short left and right maneuvers to fill the circuits and thereby purge the system of all air. After each maneuver, check and fill if necessary, the hydraulic tank. Repeat until the level remains stable.

MAX POWER

Warning: All hydraulic systems develop very high pressures. Failure of piping, connections etc that have been improperly installed will most likely happen on start up. Stay clear of these components. Wear eye protection, and be aware that high-pressure oil can cause major skin damage.

→ Check the thrust direction:

→ With the Joystick to the left (port), the vessel should move to port and conversely. If the direction is not correct, inverse to connectors on the hydraulic distributor.

Once all the above tests have checked out correctly, you may now carry out the directional control valve (DCV) adjustments and the thrust tests.

OPERATION AND USE

Operating Procedure

Switch on the system power breaker (main equipment panel).

On the control panel: (See Diagram N°11)

- Turn, the red button switch to the right. The red lamp will light, indicating that power is available, and the turbine is in the raised position.
- Pull the joystick towards yourself (aft or down), the red light will extinguish, the alarm buzzer will sound until the green light illuminates. The unit is ready for use when the green light is lit and the buzzer is silent.
- Move the joystick to the left (port), the vessel will move to the port and conversely.

Use the thruster as required. If the alarm buzzer sounds and the green light is still on during operation, stop the thruster immediately. This alarm indicates that a problem has occurred on one of the auxiliary alarms.

When finished reverse the above operation: move the joystick away from yourself (forward or up), the green light will extinguish, the alarm sounds until the red light illuminates indicating that the RETRACT is fully retracted. It is now safe to advance at normal cruising speeds.

CAUTION: Never leave the RETRACT in lowered position when not in use. The RETRACT must be in up position (retracted) when sailing.

The RETRACT is designed to be used in harbor when maneuvering at low speed (below 3 knots).

Switch off the system power breaker.

General Operating Data

MAX POWER

R450 hydraulic motor driven Series - A conservative estimate of the maximum overall and intermittent operating times for all the R models (before heat accumulation produces too high a temperature in the hydraulic circuit)

Intermittently:	15 min at 20°C
Continuous operation:	5 min at 20°C

For longer service periods, Max Power recommends an optional heat exchanger and water pump installation to provide extra oil cooling.

TROUBLESHOOTING GUIDE

PROBLEM : Thrust stops almost immediately after it has been applied. The alarm buzzer comes on and the green light turns off.

PROBABLE CAUSE 1 – The Raise/lower Electro-pump unit is not working correctly.

REMEDY : Check that the Raise/lower unit has 24 VDC power to the motor. Check that the pump operates in down position before the thruster starts.

PROBABLE CAUSE 2 - The green (B) position switches out of adjustment.

REMEDY : Readjust the green (B) position switch by loosening its securing nut and readjusting it closer to the actuator.

PROBLEM : The thruster seems to be developing less thrust.

SECONDARY CAUSE : Low oil pressure.

REMEDY : Check pressure. Consult hydraulic technician

THIRD CAUSE : Propeller problem (plastic bag, rope, etc...)

PROBLEM : The turbine retracts, but the alarm does not stop or the red light does not illuminate.

PROBABLE CAUSE : An object such as a line, plastic bag, or other flotsam is caught between the closing plate and the hull.

REMEDY : Raise and lower the unit a few times to see if the object clears. If it does not, try to remove the object manually.

WARNING NEVER put your hand into the opening of the hull.

PROBLEM : The RETRACT will not open.

PROBABLE CAUSE : No power (24 VDC) to the Raise/lower unit.

REMEDY : Check the 20 amp or 15 amp fuse breaker in the control box,
Check that wire number 5 has power,
Check that power is available to the unit, by checking the voltage on wires
n° 21 & 22 in the control box .
Check oil in the reservoir of R/L unit
Check joystick operation.

MAX POWER

The RETRACT R450 is equipped with a manual override device, which can be used for lowering the RETRACT turbine from the UP to the DOWN position.

IMPORTANT never leave the Manuel override screw unscrewed, while using the hydraulic up down unit this would result in very serious damage.

PROBLEM : The transmission lube oil tank level decreases.

PROBABLE CAUSE : The propeller shaft oil seals are worn.

REMEDY : Change the seals at next haul out. In the meantime, fill the transmission with 80 or 90 gear oil, and check the level often.

MAINTENANCE OF THE RETRACT

In order for the RETRACT unit to have a valid warranty it is crucial to respect the below:

Regular checks

1. Lower and raise several times every month
2. Transmission lubricating oil reservoir level.
3. Hydraulic power oil reservoir level.
4. Hydraulic hoses for chaffing and leaks.
5. Condition of the anodes

Control panels, like all external equipment, should be protected from the sun and weather. Clean with a soft cloth and mild detergent solution.

Yearly checks boat ashore.

1. Clean the turbine, gearbox and the propellers with a sponge and detergent soap. It is also advisable to remove the top cover plate and clean the interior of the caisson and rinse well the articulated joints.

2. Clean the surface corrosion and repaint the hydraulic motor.

IMPORTANT: If the vessel will remain out of the water for some time, for example: dry storage for the winter, the top cover plate must be removed and the RETRACT mechanism must be thoroughly rinsed with fresh water, especially the articulated joints. Do not operate below 0° C.

3. Inspect and replace all anodes of the unit. If the anodes are not consumed, check for signs of galvanic corrosion or electrolysis to the body of the RETRACT.
4. Change transmission oil, if you find water in the drive leg oil check seals.
5. Remove the propellers and check oil seals replace if necessary.
6. Inspect and repair the hull closing plate gasket for deterioration or missing pieces. Check and tighten if necessary, the plate fixation bolts.
7. Apply antifouling paint to the closing plate on the outside, on the edges and if desired to the plates inner surface. If you find growth on the unit, this is because your closing plate gasket allows light to enter the enclosure.

CAUTION: Do not use antifouling or other copper based paints on the RETRACT turbine.

8. The transmission oil must be changed each year. This can be done by extracting the sump plug screw. Never let the oil level in the lube tank descend below the level of the ships waterline.

MAX POWER

9. Check the entire hydraulic system hoses and connections for possible chaffing and leaks.
10. Every two years, drain the entire hydraulic oil system. Properly clean or replace filters in order to protect the hydraulic circuit in general.

5 YEARS

After 5 years of operation at sea it is highly recommended to completely remove the RETRACT unit and return it to the factory or an authorized service station, in order to:

1. Replace all submerged flexible hoses
2. Replace all oil seals and check for bearing and shaft wear.
3. Disassembly the unit and re corrosion treated / painted the aluminum body and the hydraulic motor.
4. Replacement of all articulation bushes.
5. Service the complete hydraulic oil system included pump, oil tank, DCV, etc.

MAX POWER

IMPORTANT

**PROJECT MANAGER'S
TEST RESULTS FORM**

**To be filled out and
faxed to MAX POWER**

MAX POWER

TEST RESULT FORM (part 1)

This form must be filled out and send to MAX POWER via email within a week after launching, in order for the standard Max Power warranty to be valid:

Date :

REFERENCE : S __ .R4__ . _____

- 11. Shipyard that installed the RETRACT:
- 11. Name of the Project Manager:
- 12. Name of the Vessel:
- 13. Type & Make of the Vessel:
- 14. Date of launching:

Please answer by YES or NO the following questions concerning the installation:

No	Description	YES / NO
1	Is the RETRACT mounted parallel to the bottom of the hull?	
2	Is there enough space for maintenance of the RETRACT and its auxiliary equipment?	
3	Does the closing plate rest upon a gasket?	
4	Is the adjustment of the closing plate done in such a way that no light is allowed to enter?	
5	Are the anodes correctly fitted to the closing plate supports?	
6	Have you fitted a cable tie in the manual lowering screw, as shown in the drawing?	
7	Is the RETRACT unit glued to the mounting base?	
8	Have you screwed the manual override screw back to its closed position?	
9	Is the pressure relief valve set to 220 bar?	
10	Are all electrical wires numbered at each end and with the terminals tinned?	
11	Is the electrical supply to the remote control box constant and stable?	

MAX POWER

When all the tests have been completed as per the manual, please record the following measurements where applicable.

With the engine(s) running, thruster in the down position, but not running:

1. Record the voltage at the remote control box: Volts

With the engine(s) running and the thruster running (either direction):

1. Record the voltage at the remote control box: Volts
2. Record the hydraulic pressure: slow speed Bars
3. Record the hydraulic pressure: full speed Bars
4. Record the hydraulic flow: slow speed Bars
5. Record the hydraulic flow: full speed Bars
6. Record the hydraulic pressure on the up/ down unit:Bars

Other comments:

DATE OF TESTS:

LOCATION:

PERSON RESPONSIBLE:

SIGNATURE:

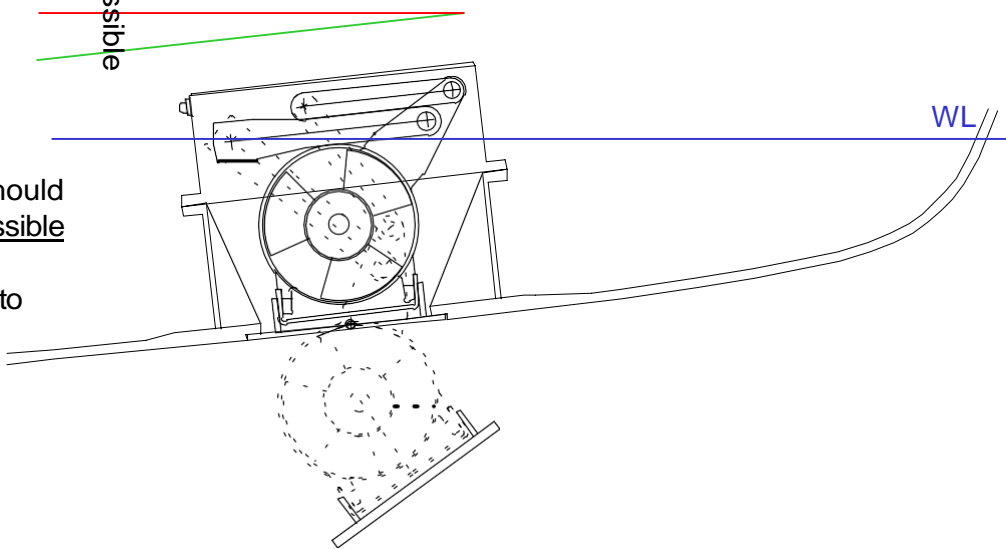
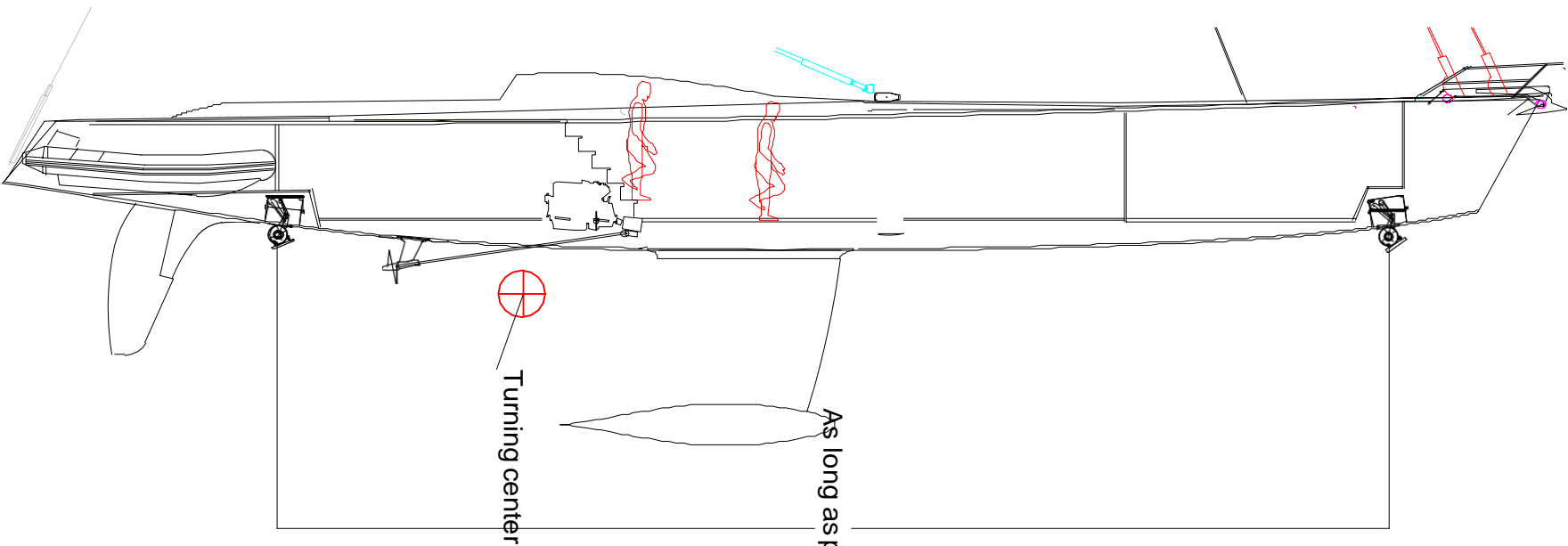

A minimum immersion depth of one full turbine diameter should be respected with the thruster positioned, as forward as possible for bow installation or as aft as possible for stern installation. The thruster must be parallel with the bottom of the hull not to the water line!

MAX POWER

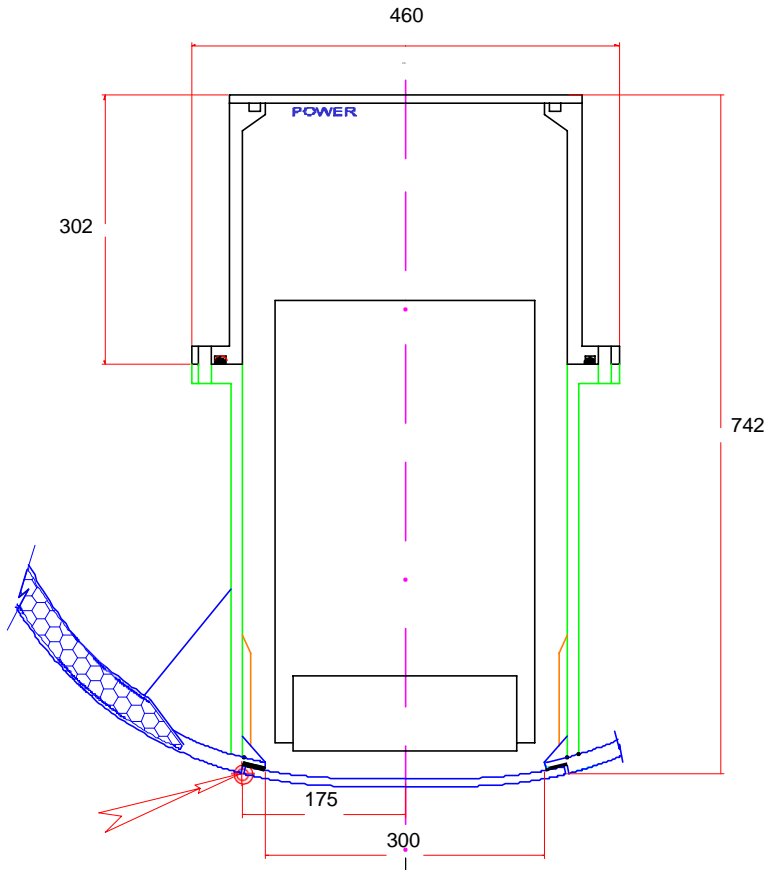
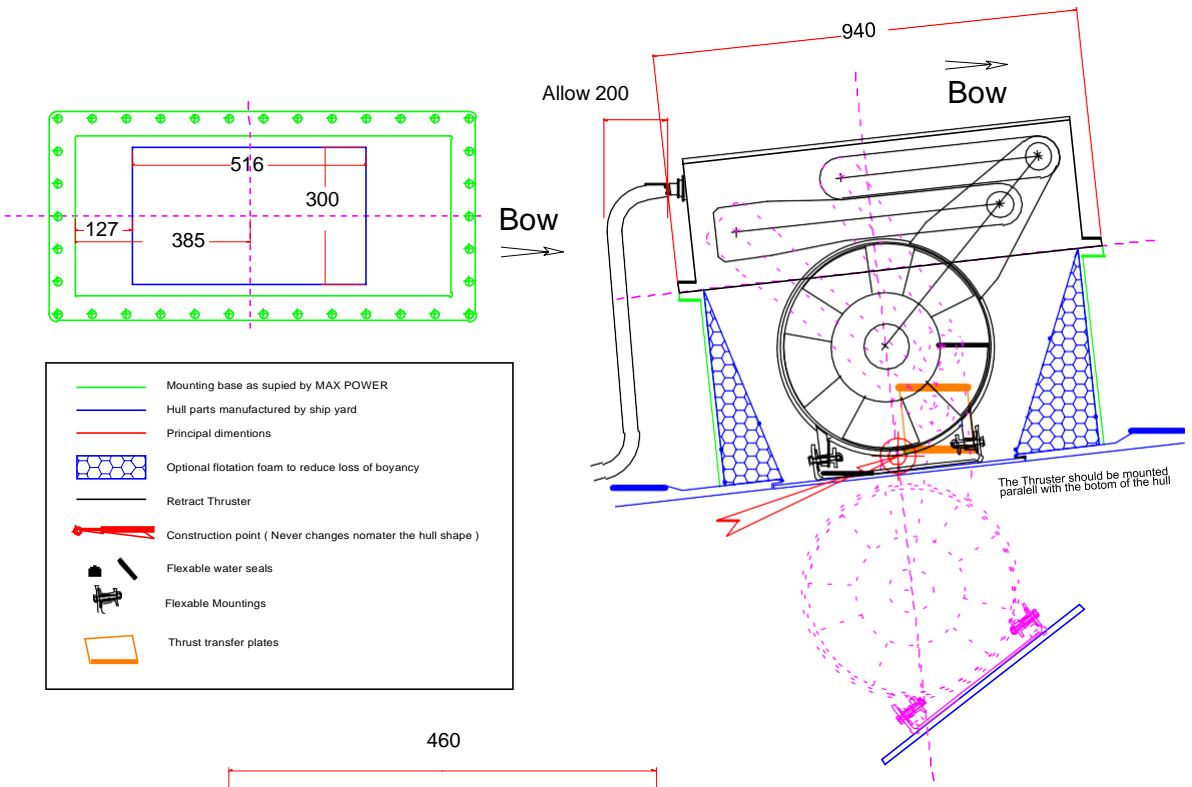

RETRACT R450 PRINCIPAL DIMENSIONS	
17/4/00	YT Turbo CAD

MAX POWER

REVISION PART NO.

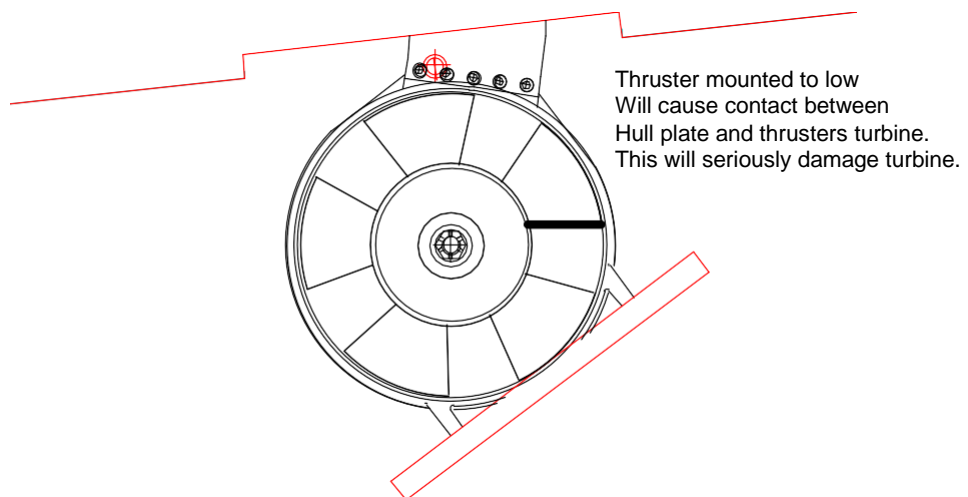
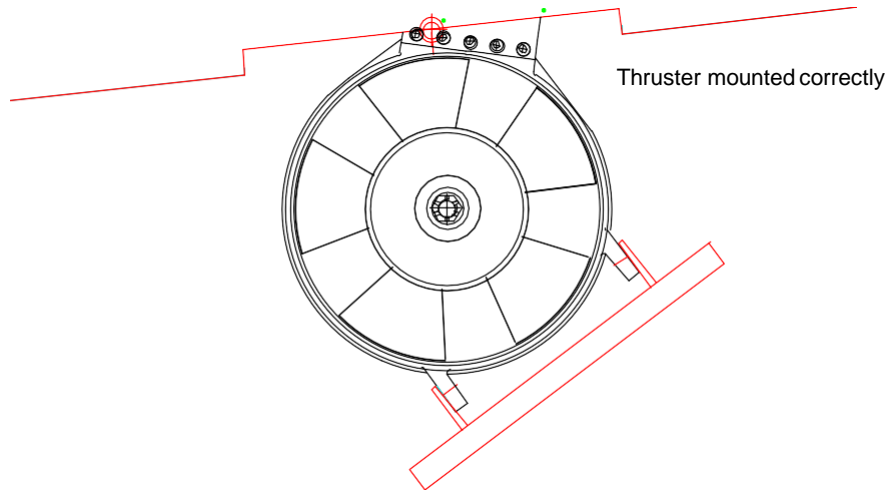
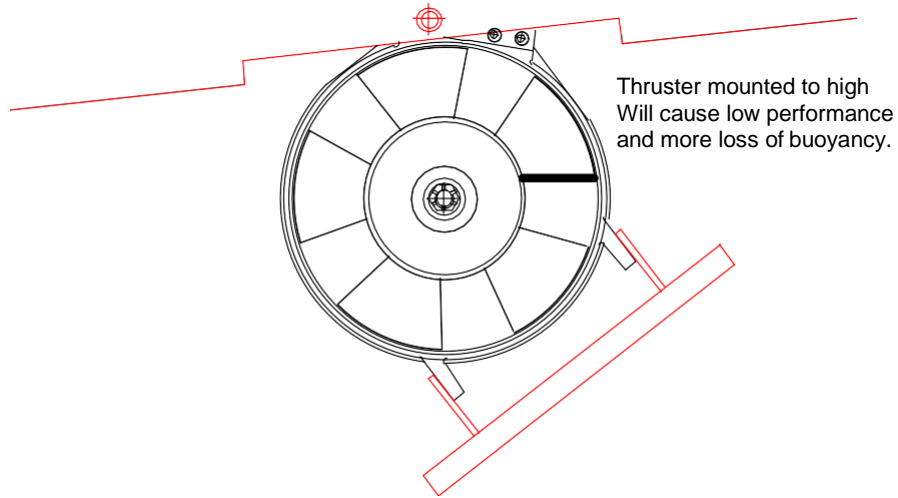

REVISION PART NO.

TITLE
UNLESS OTHERWISE SPECIFIED

CONSTRUCTION POINT ERRORS

MATERIAL	
Max Power	
DRAWN	CHECK/RELEASE HEAT TREAT & FINISH
DATE	DATE
03/05/01	

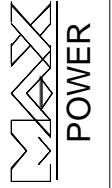

MAX POWER

Closing adjustments (lock)

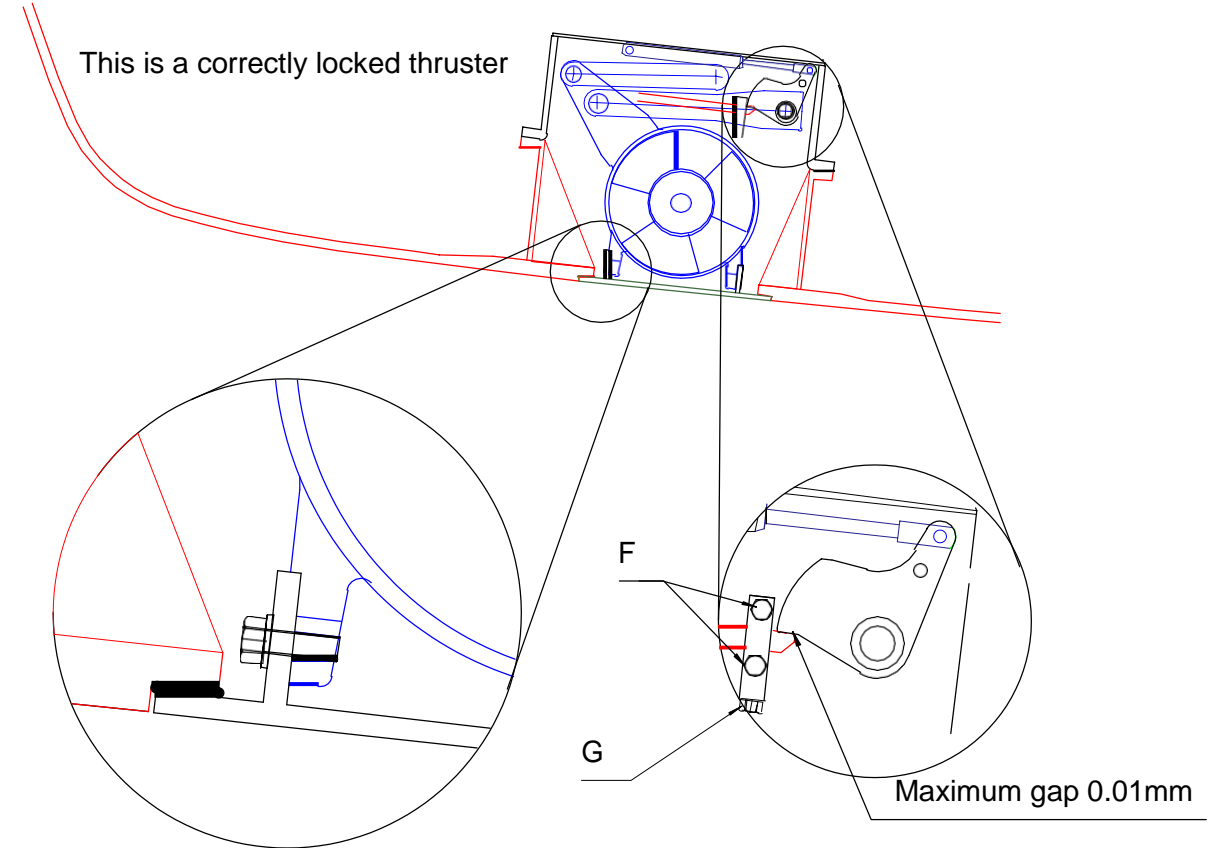

Closing adjustments (closing plate)

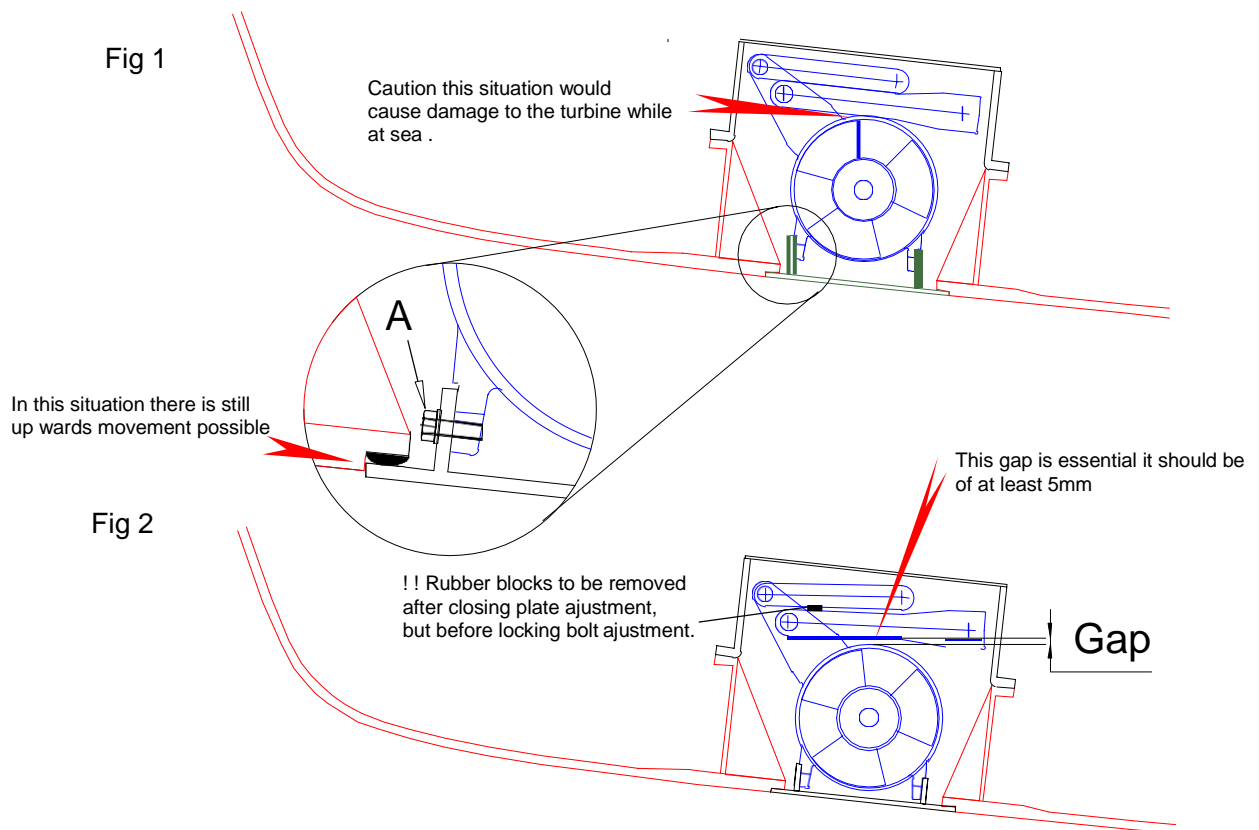

Thruster up and locked

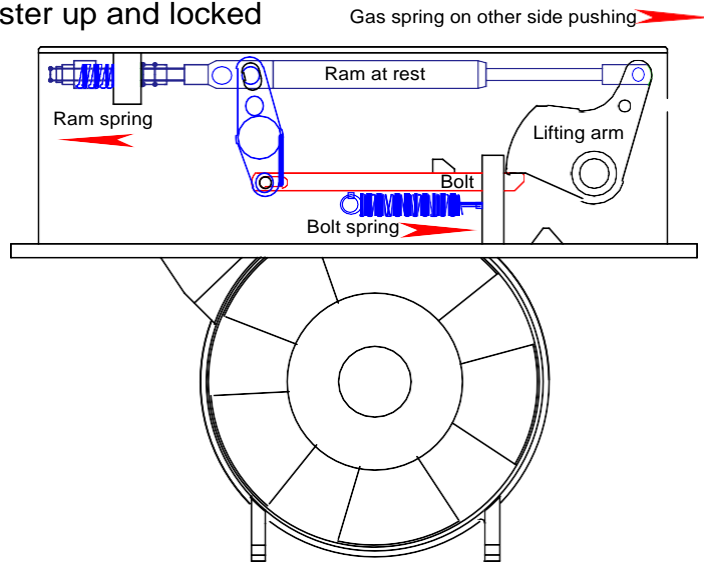

Thruster unlocking

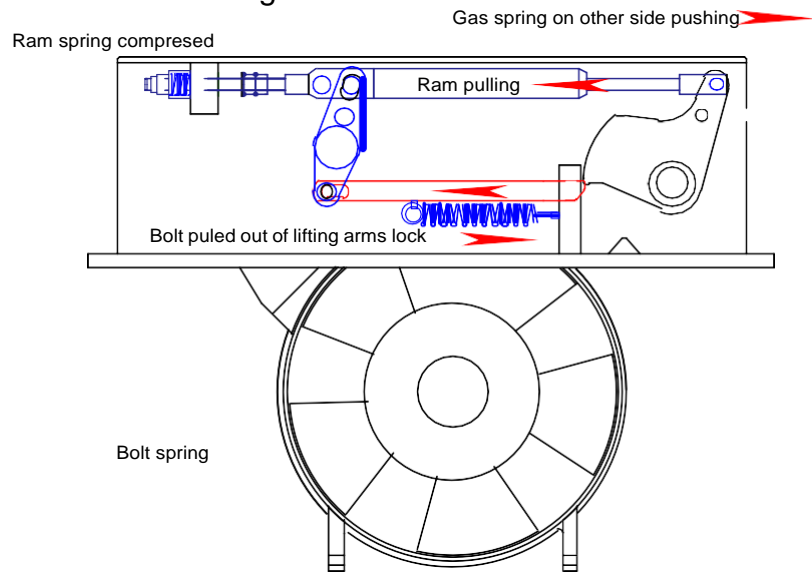

Thruster down

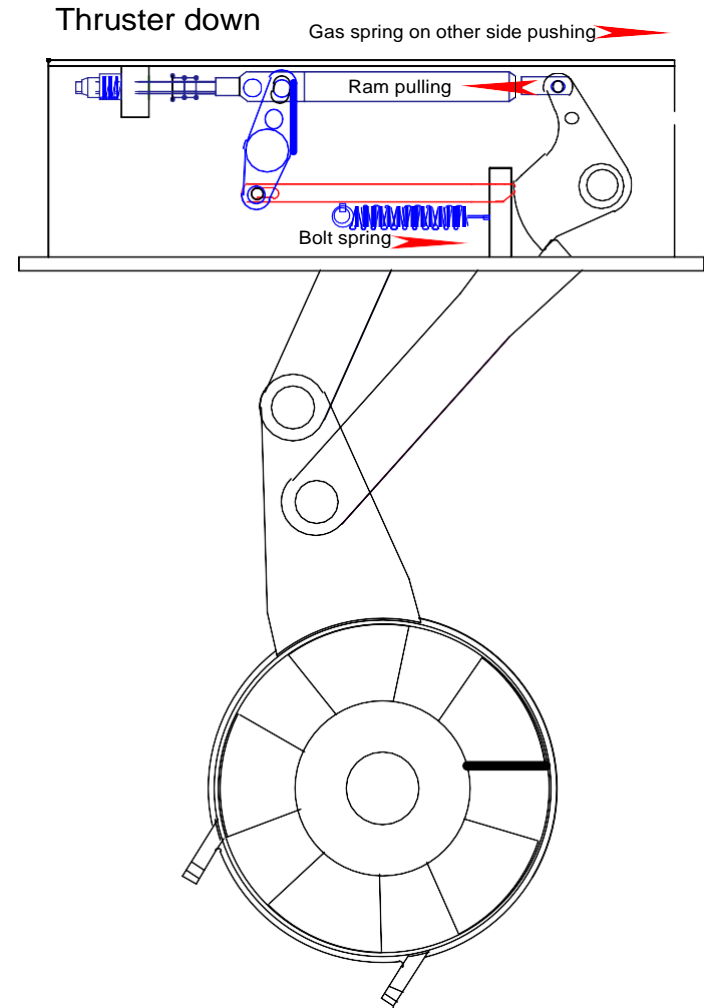

MAX POWER

R450 locking system

MAX POWER

Manuel operation

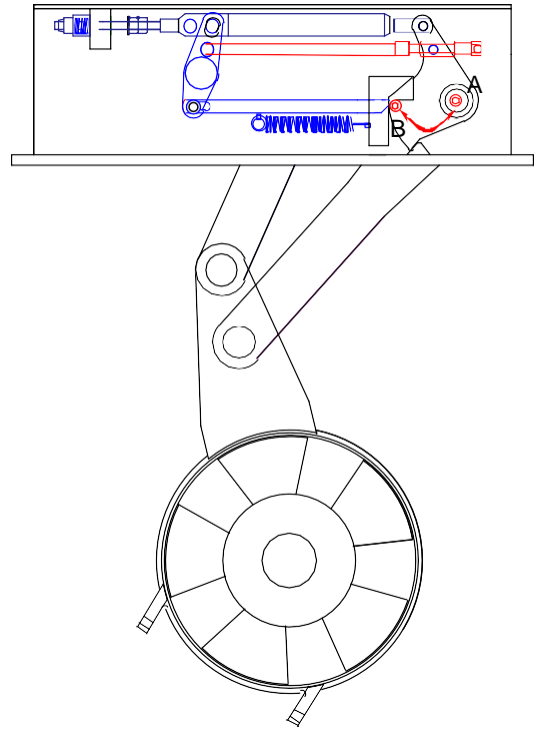
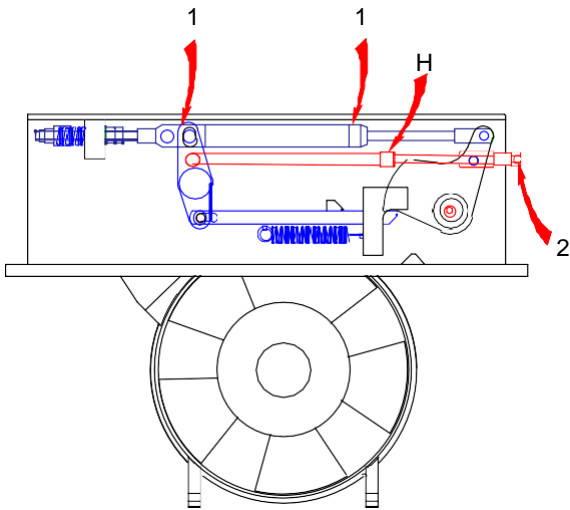

To use manual lowering screw

- 1 Disconnect hydraulic connections on ram A&B (or energize up down unit control valve)
- 2 Turn manual lowering screw clockwise
- 3 Place security bolt (A) in thread hole (B) before working on the unit.
- 4 When finished reverse operation making sure that when raising the unit the thruster follows the up motion progressively.
- 5 Be sure to return screw to fully unscrewed position and to re fit a cable tie threw the lowering screw and its thread at point (H).

Failure to do this can result in serious damage to the turbine.

Proximity switches

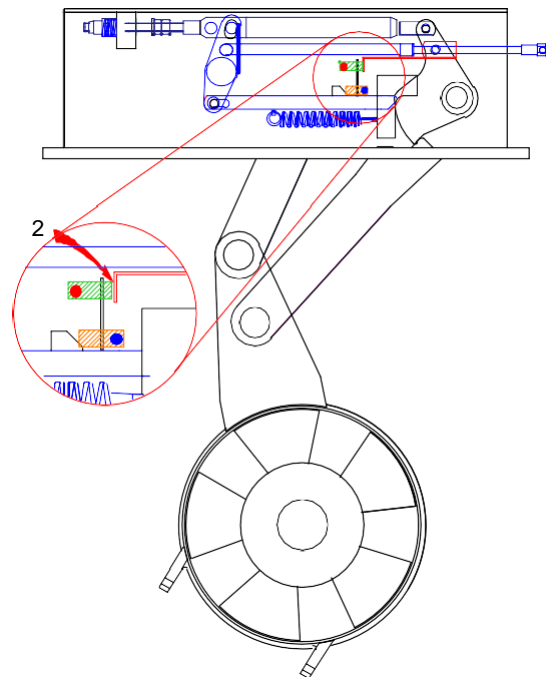
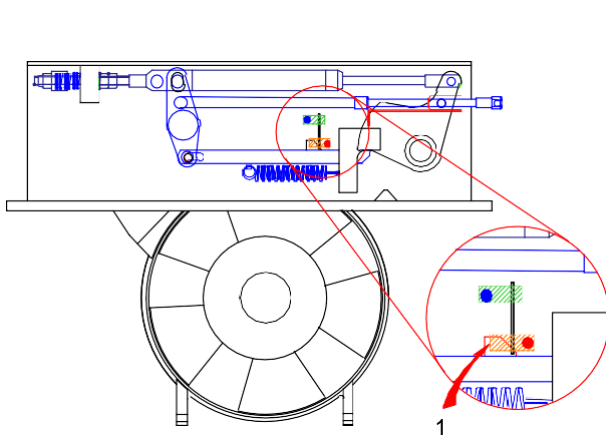

The proximity switches on the thruster indicate to the control box in witch position the thruster is in.

- 1 This indicates that the thruster is up and locked .The detector bar is on the lock therefore if the alarm is sounding the thruster may be up, but is not locked!
- 2 This indicates that the thruster is down and can therefore thrust. Should at any moment the unit come of this position when running it will automatically stop. Due to the use of the gas ram the unit will also slide of this stop if not used for more than 2 min.

Control system wiring diagram R450

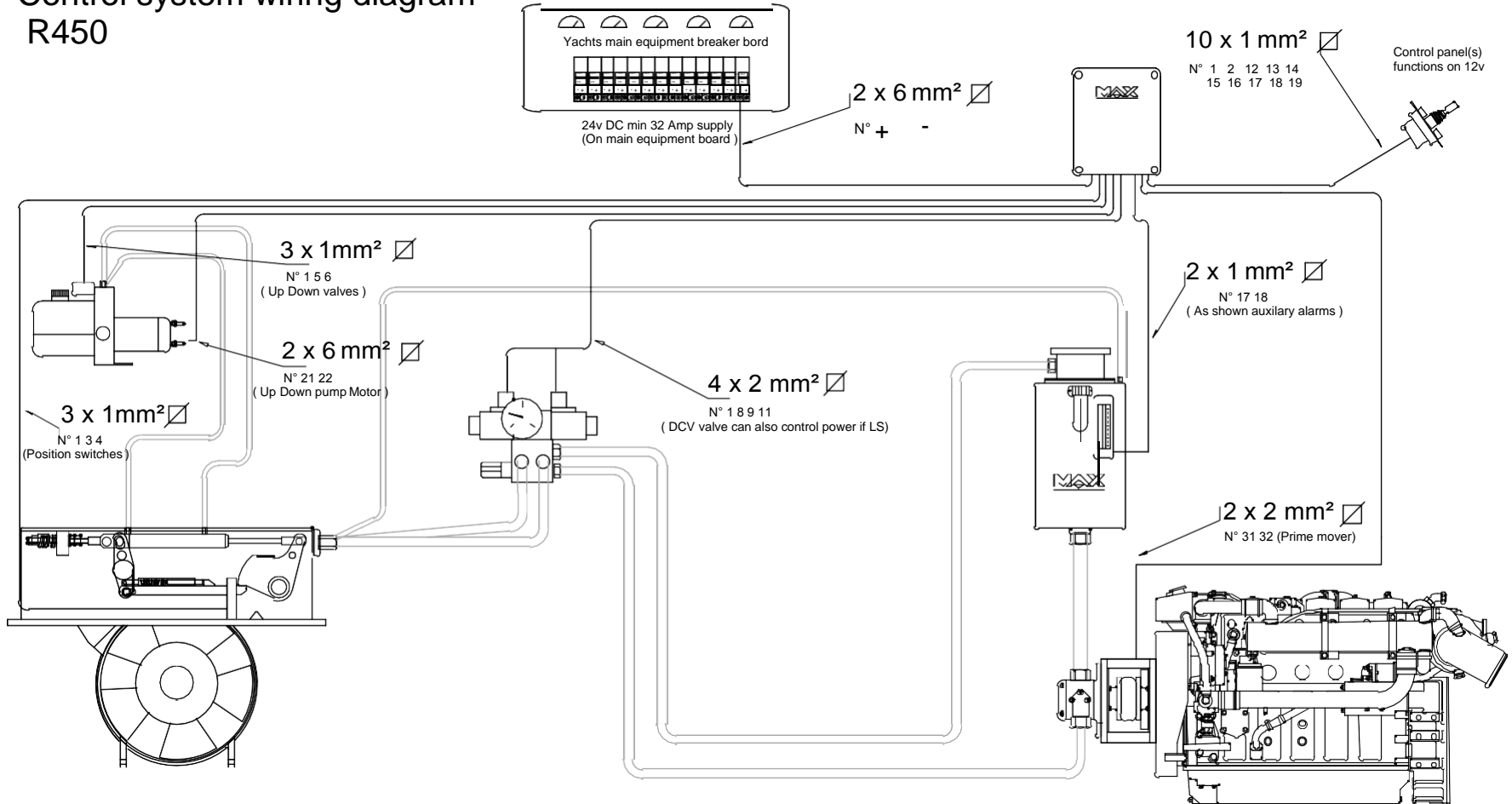

MAX POWER

MAX POWER

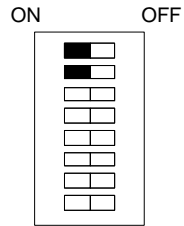
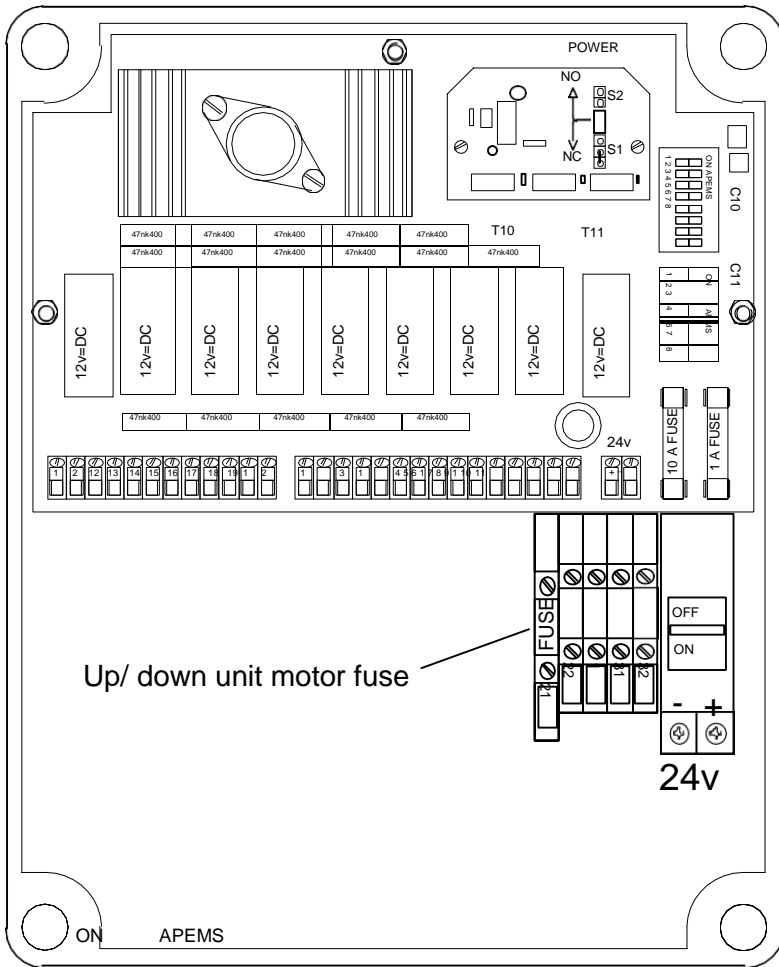

Switch bar C10
The more bars are on the longer the time delay before port 31&32 energize

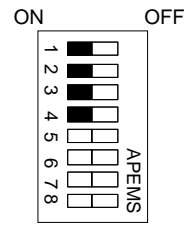

Switch bar C11
The more bars are on the longer the delay before port 11 switches on in NO Programming or off in NC Programming

2 3 4 5 6 7 8

T10 T 10 indicates prime mover status
Ports 31 neg. and 32 pos.

T11 T 11 Indicates bypass status
port 11 and any 24v neg.

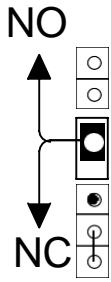

Switch indicates normally closed NC
Or normally open bypass option NO

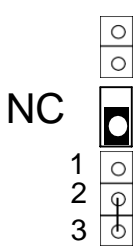

S2 only functions when switch is set on NC bypass mode
Shunt on = end of cycle bypass for 1/2 sec
Shunt off = end of cycle bypass for 1 sec

S1 only functions when switch is set on NC bypass mode
Shunt between 1 & 2 = bypass will open at end of cycle
Shunt between 2 & 3 = bypass will not open at end of cycle

MAX POWER

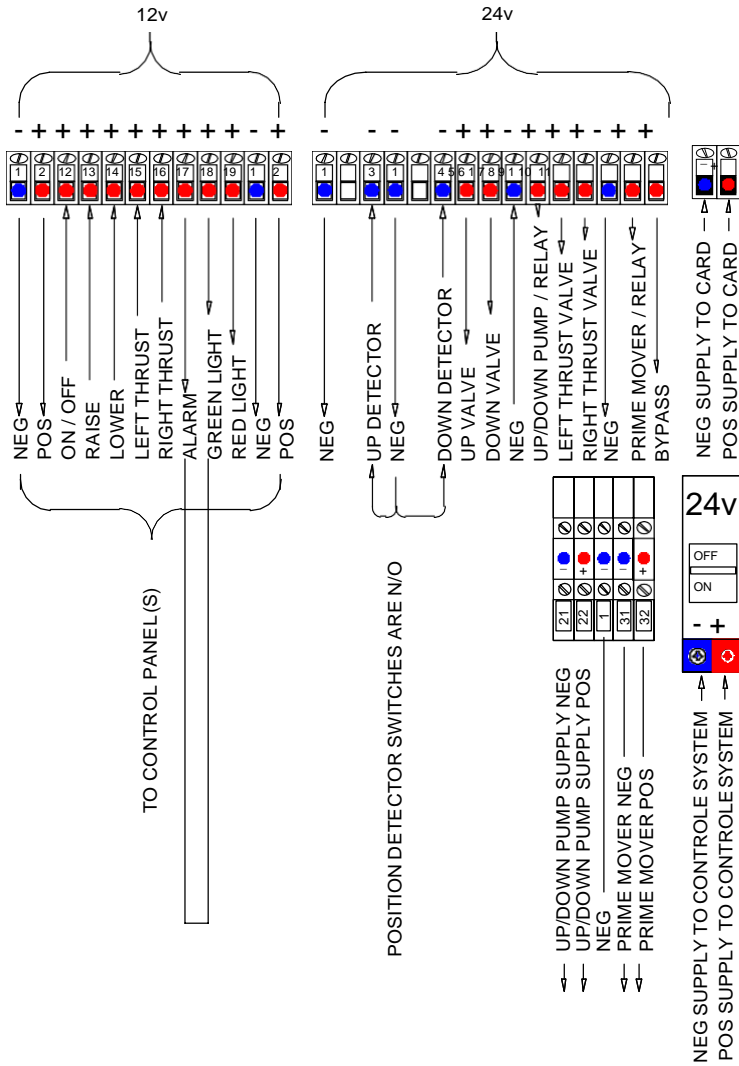

Plan for custom panel

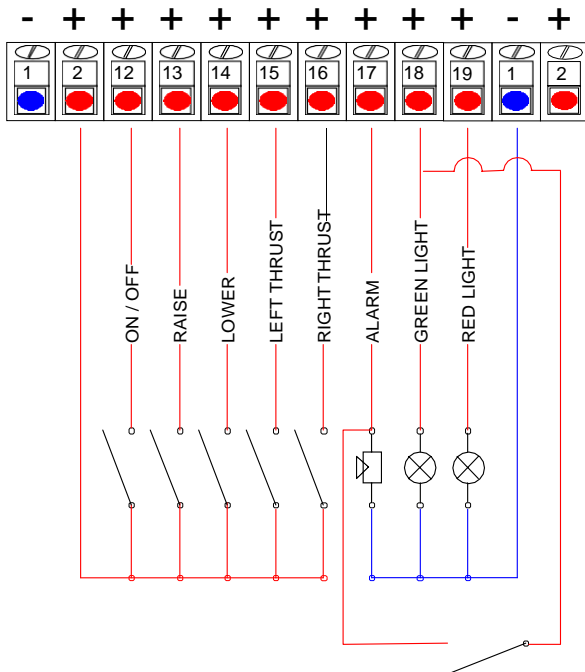

Foot switch /custom control panel

All control switches used should be of N/O momentary push button type with the exception of the on/ off which should be of switching type

Any N/O switches or sensors can be used for complementary alarms at will

MAX POWER

Standard (retired) panel

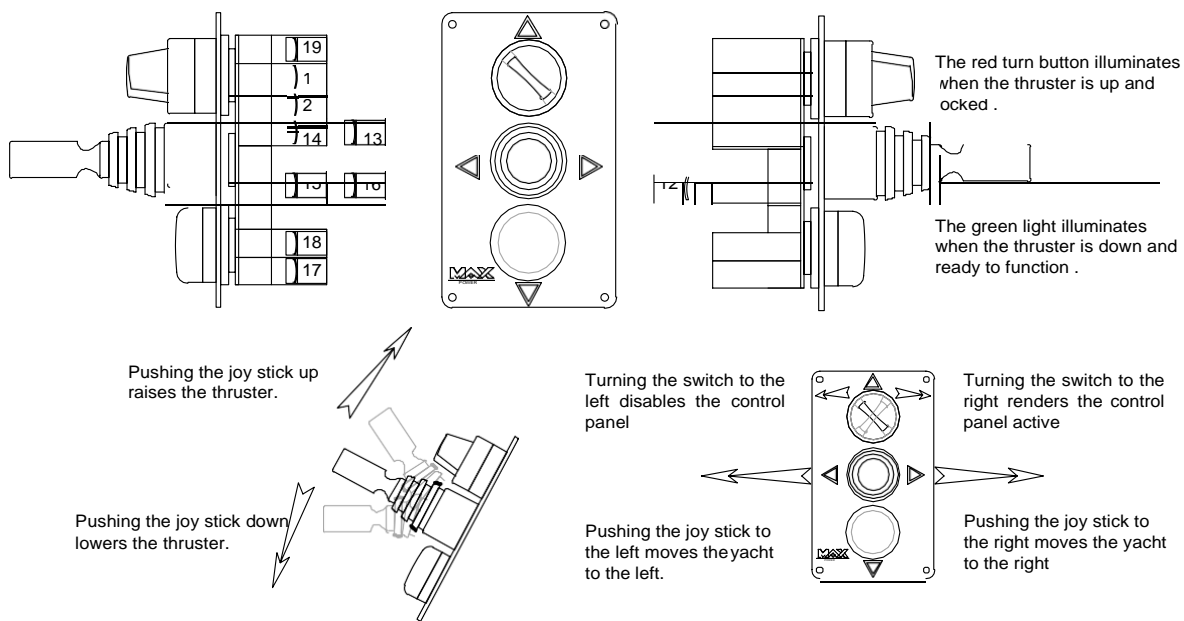

Service & closing plate fixations

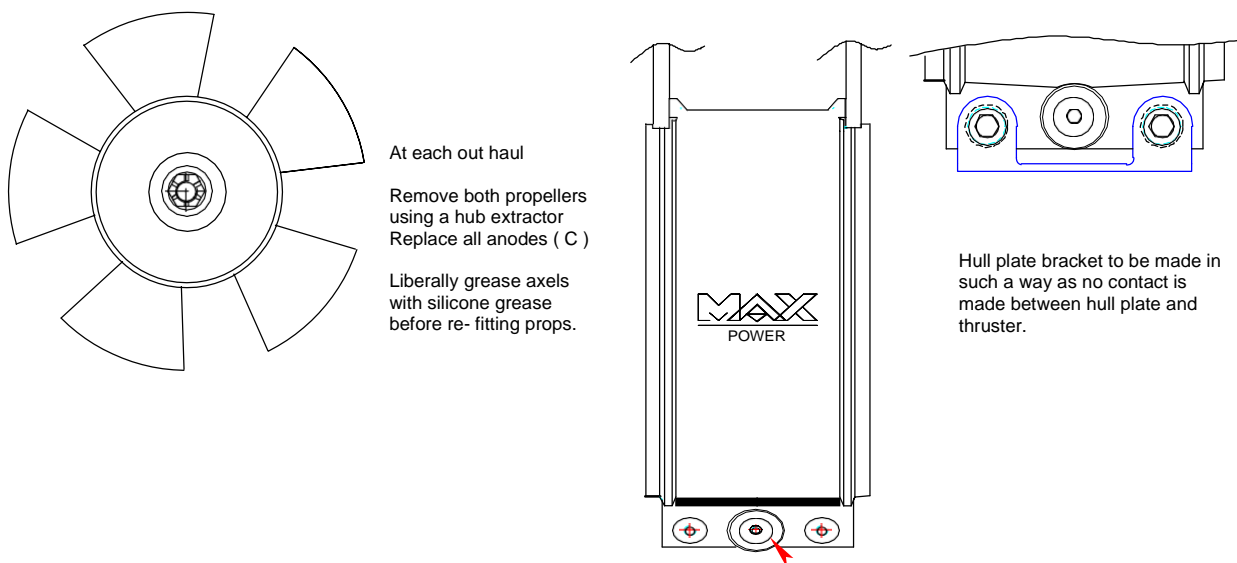

MAX POWER

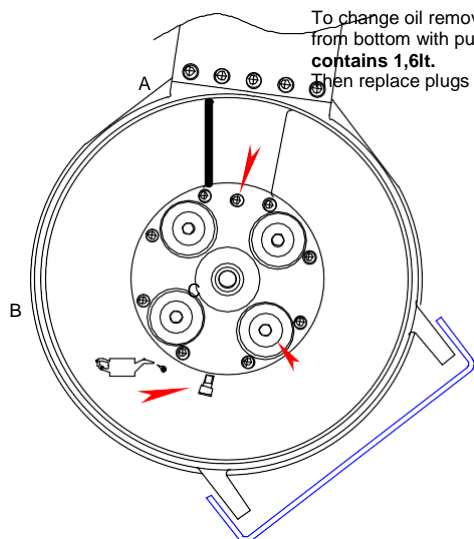

To change oil remove both Plugs A & B thoroughly drain Fill from bottom with pump until oil comes out of A . Drive leg contains 1,6lt. Then replace plugs changing the o ring seals.

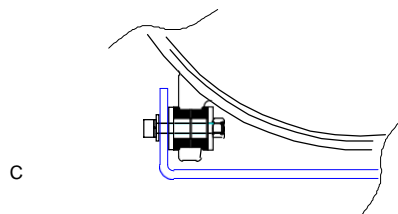

The hull plate bracket (Shown in blue) should be fixed to the Thruster only by means of the rubber silent blocks and under no circumstances directly to the cast alloy turbine housing.

WARRANTY COVERAGE

Introduction

The purpose of this document is to set out the terms of warranty cover offered in relation to products purchased by the End User from Max Power or its approved network of resellers. This document will adhere to the following format:

Section 1	Definitions
Section 2	Period of Coverage
Section 3	Warranty Registration
Section 4	Warranty Terms
Section 5	Warranty Exclusions
Section 6	Procedural Guidelines
Section 7	Service Centers

1) Definitions

Authorized Repair Number – The number given by Max Power on reporting a fault with your thruster

Dealer – An authorized Max Power sales centre

End User – The boat supplied with supplied equipment and the owner thereof *Installer* – The authorized centre responsible for the installation of your thruster *Manufacturer* – supplier of the equipment under warranty

Pleasure Craft – Vessels used for owner's personal use that have no commercial use (i.e Charter boats or work boats)

Resellers – Max Power approved distributors and dealers

Serial Number – Number in upper right hand corner of Warranty document

Supplier – The manufacturer (Max Power)

Warranty – The terms and conditions that are covered by the manufacturer

2) Period of Coverage

The equipment manufactured by the Supplier is guaranteed to be free from defective workmanship, components and materials under normal usage conditions for a period of two years from the date of purchase by the End User. This warranty is transferable to subsequent owners of this equipment during the period of coverage.

MAX POWER

3) Warranty Registration

Register your purchase now to receive free extended warranty coverage. This can be done using one of the following methods (NB. proof of purchase must be included to establish that equipment is still under warranty):

The quickest and easiest method to register your warranty is to send the attached installation check list and warranty registration to the Manufacturer via email or fax:

(Fax: +33 4 92 19 60 61)

Mail in your warranty registration document, please ensure that you make a copy before sending it.

4) Warranty Terms

If the material is used for anything other than for pleasure craft, the guarantee is limited to a six-month period.

Year 1 -All factory testing, diagnosis, repairs and replacements are performed at no charge to the End User. All parts and up to two hours of labor are covered for repairs and replacements conducted in the field.

Year 2 -All factory testing, diagnosis, repairs and replacements are performed at no charge to the End User. This excludes any damage or faults occurring from normal wear and tear on the following items: engine, oil seals, relay contacts (If warranty is registered within the 3 month period following installation)

5) Warranty Exclusions

Damage due to modifications or installation contrary to published specifications

Damage due to electrolysis or galvanic corrosion between the hull and the RETRACT body

Cost of hauling the boat

Damage due to repairs performed by an unauthorized service centre

Damage due to lack of normal maintenance services

Damage due to water

Parts replaced due to normal wear and tear

Repairs performed without knowledge of manufacturer (please contact dealer to receive Repair Authorization Number)

Tampering of equipment by the End User Cost of travel to and from the job site

Cost of economic loss, including injury to any person, damage to property, loss of income or profit, communication, lodging, inconvenience

Consequential damage due to failure, including those arising from collision with other vessels or objects

MAX POWER

6) Procedural Guidelines

PLEASE VIEW THE TROUBLE SHOOTING LIST TO ASCERTAIN OR SOLVE ORIGIN OF PROBLEM PRIOR TO CONTACTING THE DEALER/INSTALLER

Contact your dealer/installer to report the problem.

If you do not know who this is contact the nearest Max Power distributor

If you are in foreign waters please contact the nearest Max Power distributor

Ensure you have your serial number and model number to hand (top right hand corner of warranty)

Dealer/Installer will come to site to decipher the cause of the fault

If the cause of fault is due to a manufacturing problem the dealer will contact Max Power to receive Repair Authorization Number.

If the problem is due to an installation error please contact your installer.

IF POSSIBLE: PLEASE TAKE PHOTOGRAPHS OF THE THRUSTER TO SHOW PROBLEM

The warranty as outlined above is only applicable to Max Power manufactured thrusters and optional equipment as used in marine pleasure industry. The supplier holds the exclusive right to test the product and determine whether it is defective